

The Johnston V Range

VT651 VS651
VT801 VS801



Operational Performance

The V Range has established itself as an industry standard by implementing over 50 years of continuous improvement, resulting in a vacuum sweeper that is the most cost-efficient and dependable while ensuring maximum performance is always achieved. Johnston Sweepers offers a wide choice of options and chassis models to suit specific operational requirements that will bring out the best performance in vacuum street sweeping.

- In-cab controls are ergonomically positioned to provide safe and easy operation while sweeping.
- Throttle control of the auxiliary engine is infinitely variable ensuring optimum operational and fuel efficiency with no performance compromised. With a 1500 rpm Eco-mode built into the V Range, fuel conservation is enhanced and noise levels are reduced.
- Pendant controls connected via a flexible cable allows the operator to safely tip the body and open rear door from inside or outside of cab, and on either side of cab at the same time.
- To extend brush life, the wide-sweep brush can also be adjusted using the pendant control.
- As standard, all Johnston V Range sweepers are fitted with a full-width body prop which automatically engages when the hopper is raised, with a choice of four tipping heights.
- The auxiliary engine and hydrostatic drive pump are accessed via a wide lightweight service ladder giving constant three-points of contact for the user.
- All V Range models have equipment lockers on both sides of the hopper for storage of hydrant or Aluminum Catch Basin extension tubes.
- All critical controls – including valves, solenoids and auxiliary equipment for pneumatic, hydraulic and water systems are contained in a systems control locker on the right hand side of the vehicle. The ease of access to this equipment aids diagnostic checks and maintenance. Additionally, the V Range is also fitted with certified IP67 electrical connectors, an industry standard meaning the connectors are waterproof and dust-proof.
- As standard, the V Range sweeper features a Pressadrain water purging system so that when freezing weather conditions are anticipated, water is easily and conveniently drained by operating a simple in-cab switch.
- Water jets in the nozzles are self-cleaning using “pressure-loaded” pins to make certain all high wear components are saturated with lubricating water.



Johnston CANbus System Advantage

The Johnston CANbus system monitors sweeper performance and provides daily checks. The display incorporates as standard an audible and visual raised hopper warning, fuel gauge, engine hour meter, tachometer and a water level gauge. In addition, data can be downloaded via a USB stick, recording various items of data for better cost control and easy analysis of sweeping operations.

- **Human/Machine Interface**
 - ECO mode
 - Color Coded operating zones.
 - Key operating fuel consumption displayed.
 - Performance improvement through better ergonomics and intelligent functionality.
 - New V Range has half the number of sweeping controls versus competitive units – ideal for the novice operator while retaining the ability for an experienced operator to quickly tune the machine.
- All sweeping controls moved to the door post – GB position controlled by joystick.
- In-cab pendant control of WSB adjustment.
- Semi-automatic winterization - Pressadrain.
- Fuel & water gauges all in cab.
- **Data Acquisition For Management**
 - Data Capture – If you can't measure it, you can't control it!
 - Easy analysis of key data by USB flash drive and upload into Excel – Hours swept, auxiliary rpm, fuel consumption, next/last service, etc.
 - Easy comparison between machines and operators.
 - Ability to restrict the operation of the machine within given parameters.
- **Diagnostics**
 - Important warnings are indicated on the main screen and direct the operator to the source of a problem.
 - A multitude of additional diagnostic data is provided by pressing F3. This can either allow the operator to diagnose the problem or provide accurate information to a service center.
 - Ability to open hopper door and lift the hopper with auxiliary engine turned off.



Nirosta® In My Body

Johnston is the only sweeper manufacturer to offer as standard, "Complete Hopper Constructed of Stainless Steel"- not lined. We don't use just any stainless steel. We exclusively utilize Nirosta® Stainless Steel - the very best for this application.

Johnston sweeper bodies provide 250-times better corrosion resistance than mild steel and our abrasion resistance is not only better than mild steel, but also better than 304 stainless steel. Our commitment to this level of excellence is what has gained us the commanding position in the vacuum sweeper marketplace.

Johnston is the only company to give a "Life-Time Warranty" with our stainless steel hoppers. We are the only manufacturer to offer a "Complete Stainless Steel Water Tank" in our vacuum sweepers. It too has the only "Life-Time Warranty" in the industry.

Johnston provides superior corrosion and abrasion resistance prolonging and extending component life resulting in no maintenance and increased productivity.

Johnston offers the best performing vacuum product on the market and the lowest ownership costs, and best warranties.



The Johnston Standard

- Complete Stainless Steel Hopper
- We exclusively utilize Nirosta® Stainless Steel
- Better corrosion resistance than mild steel
- Abrasion resistance better than mild steel
- Abrasion resistance better than 304 stainless steel
- Complete Stainless Steel Water Tank
- Superior corrosion and abrasion resistance
- Lowest ownership costs and best warranties
- Only "Life-Time Warranty" in the industry



Productivity

The V Range provides the ideal balance between performance, environmental impact and low cost of ownership, with applications to suit a full range of sweeping environments - benefits that make the Johnston V Range the sweeper of choice worldwide.

Two drive options (VT and VS) provide outstanding vacuum performance. On the VT Range, JCB and John Deere auxiliary engines combined with the Johnston mechanical step-up gear box and fluid coupling, and the Johnston hydrostatic gear box drive on the VS model, provide the best efficiency ratios in the industry.

The versatile VT Range powerpack with a range of 1200 rpm – 2000 rpm, can operate efficiently in municipal environments at a lower rpm, or for one pass heavy duty resurfacing operations, the engine provides full power to ensure a clean path is all that is left behind.

The V Range offers numerous sweep configurations from a nozzle with only 30-inch sweep path to a simultaneous sweep path of 144 inches.

A stainless steel water tank is integrated into the floor of the hopper body, which provides ideal weight distribution between axles, and weight transfer during sweeping.

Dust and debris are collected by pneumatically operated vacuum nozzles and wide diameter 10 inch nozzle trunking, maximizing velocity and allowing larger debris to pass easily into the hopper.

Debris is sucked in a direct route from the vacuum nozzle into the hopper, reducing wear and tear as well as maintenance. Once in the hopper, the Johnston cyclonic airflow helps separate the debris, and clean air is then released into the atmosphere.



Accessible systems locker with LED service light.

Supawash front spray bar.

Supawash hand lance in action while servicing catch basin.

Powaboom option cleaning catch basin.

Variable lateral control Varibrush option.

TOP Rotatilt Brush Option.

New screen latching system for ease of use.

New standard engine cowling sound suppression.

New wider access ladder.

MIDDLE PM10 spray bar.

BOTTOM Self-cleaning nozzle spray jets.



Johnston VT651: The Industry Leader

- Johnston's popular VT651 has a hopper volume of 8.5 yd³ and water tank capacity of 415 gallons. The VT651 is compatible with GVWR 33,000 lb chassis.
- A Johnston VT801 truck mounted sweeper comes with a high powered engine as standard and a hopper volume of 10.5 yd³. The water tank capacity is increased to 534 gallon and is well matched to a GVWR 35,000 lb chassis.

All Johnston V Range models are built with an angled hopper floor, enabling a total discharge angle of 55° (model dependent) to aid load discharge.



Blower Drive System

The V Range blower drive system carries a full 5-year comprehensive warranty. The gearbox ratio of 1:1.79 equates to a fan speed of 3580 rpm. Virtually maintenance-free; there are no belts to adjust on a daily basis or replace within a year of operation.

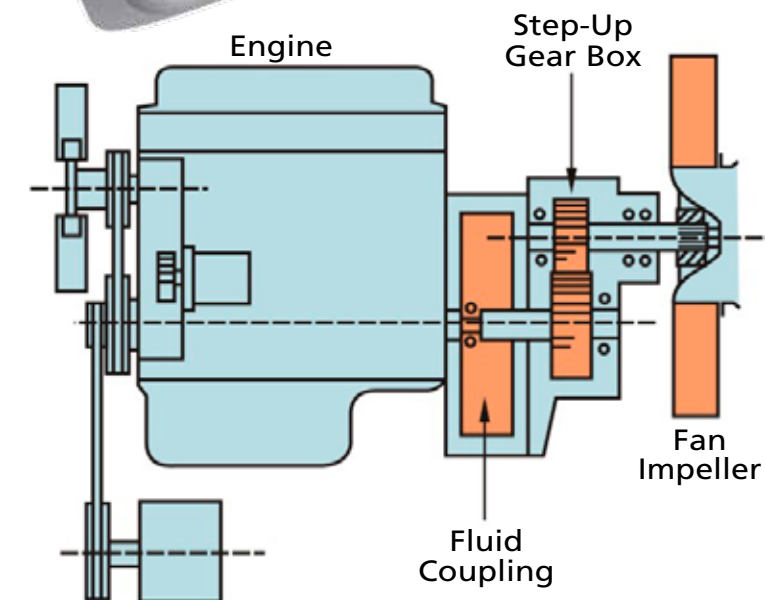
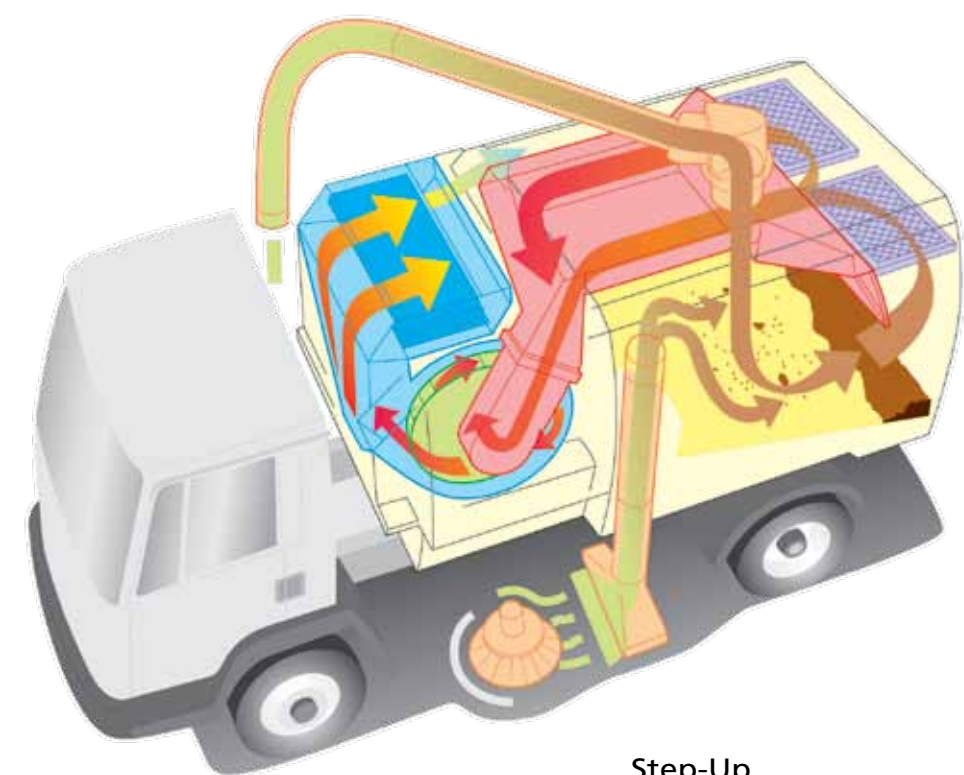

Environmental Impact

Manufactured in a factory accredited to ISO 14001 for sustainability, Johnston is committed to providing the most environmentally sustainable equipment on the market for collecting all types of debris and litter.

Low fuel consumption is a key attribute in reducing carbon footprint and CO₂ emissions. With the mechanical drive systems running at maximum efficiency, the fuel consumption of the auxiliary engine is the lowest in its class with 0.87 gallons per hour at 1200 rpm.

The VT Range is now fitted with auxiliary engines supplied by JCB and John Deere, whose engines meet the highest standards for emissions and environmental impact.

Dust emissions are controlled to the highest standards, and PM10 atomizers suppress dust to meet EUnited PM10 Standards in Europe, and in America, SCAQMD Rule 1186.

Water recirculation not only provides extended sweeping shifts but can also save 237.7 gallons of water per day over an 8 hour shift.

The V Range sweepers are equipped with noise suppression hoods, encapsulating the auxiliary engine and fan casing. Noise at the driver's ear is less than 65 dBA at maximum rpms (chassis dependant), creating a safer operating environment for both driver and pedestrians. The fully variable engine can be set to lower rpms for night sweeping which reduces the noise levels by 50%.

The Johnston V Range is robustly constructed from quality materials and designed to provide years of continuous performance and reliable service. End of life disposal is enhanced by the V Range sweeper being almost 100% recyclable.



ABOVE
Stainless steel hydraulic lines, wider blower intakes, and new improved body safety prop automatically deploys.

BELOW
Optional full-width nozzle option between the axles.



Cost of Ownership

V Range sweepers operate at the lowest costs, with a large 50 gallon auxiliary fuel tank giving increased on-station time. In addition, maintenance costs are significantly reduced on the Johnston gearbox and fluid coupling, as no belts or high wearing components are required.

Johnston's VT Range provides the lowest emissions and running costs. The VT and VS models operate at low fuel consumption with both the chassis and auxiliary engines using a total of 1.33 gallon/hr at low rpm. In addition, suction sweeping requires fewer component parts, thus resulting in less wear and tear and reducing maintenance costs.

Designed to last in the toughest environments, the V Range hopper is manufactured from 4003 stainless steel, shot blasted with aluminium oxide prior to the application of a strontium based primer followed by a hard wearing top coat. In addition, all grey parts such as the sweepgear, powerpack and subframe are shot blasted and electro-magnetically powder painted in a durable two part epoxy paint finish. This ensures the sweeper continues to look as good as it performs, retaining a high residual value or longer in-service life.



Additional Features

Johnston provides a comprehensive choice of options all designed to maximize versatility and performance:

- **Supawash** • A high pressure water jet, enables the operator to clean street fixtures and pavements using either a fan or pencil jet spray. The lance and 50-ft hose stows away neatly when not in use. In addition, high pressure water jets on a spray bar are positioned on the front of the cab, and others placed behind the nozzle boxes to provide dust suppression when sweeping.
- **Hydraulic Catch Basin Cleaner** • An optional Hydraulic Catch Basin Cleaner mounted on the top of the hopper can be fitted to allow the emptying of drains to storm drains. If "Powaboom" is selected, hydraulic controls are fitted to make the operation easier, while the top-mounted position provides greater access to both sides of the sweeper, and also shields the driver from oncoming traffic.
- **Wide Sweep Nozzles** • Twin 48-inch vacuum nozzles that deliver 96 inches of pure vacuum sweep path.
- **Rear mounted Littasnatch** • 18-ft long lightweight suction tube for collection of debris on pavements and areas out of reach of the sweeper brushes.
- **Rotatilt** • Controlled from inside the cab, this option allows the gutter broom to tilt and sweep irregular and contoured curbs, and gutters.
- **Weed Ripping Brush** • A heavy duty brush with thick metal tines that effectively clears vegetation that is growing and established in gutters.



Johnston North America Inc.

606 A&B Performance Road

Mooresville, NC 28115

Tel: 704.658.1333

Fax: 704.658.1377

E-mail: info@johnstonnorthamerica.com

johnstonnorthamerica.com