

DCL1000SE

Automated Self Contained Leaf Collector



Owner's Manual
Safety Manual
Pre-Operating Manual
Operating Manual
Maintenance Manual
Service Manual
Parts Catalog

2022 Edition

XTREME VAC
5118 Glen Alden Drive
Richmond, VA 23231
800-446-9823



DCL1000SM



CAUTION

**DO NOT ATTEMPT TO OPERATE
OR REPAIR
THE LEAF COLLECTOR WITHOUT FIRST
READING AND UNDERSTANDING THIS
MANUAL**

IF YOU HAVE ANY QUESTIONS CONCERNING THE
INSTALLATION OR OPERATION OF THIS UNIT, PLEASE CALL
ODB FOR ASSISTANCE BEFORE ATTEMPTING TO REPAIR OR
OPERATE THE UNIT.

**IMPROPER USE OF ANY MACHINE CAN
RESULT IN SERIOUS INJURY!**

**STUDY AND FOLLOW ALL SAFETY
PRECAUTIONS BEFORE OPERATING OR
REPAIRING UNIT**

THIS MANUAL IS AN INTEGRAL PART OF THE LEAF COLLECTOR AND SHOULD
BE KEPT WITH THE UNIT WHEN IT IS SOLD.

**ODB COMPANY
5118 Glen Alden Drive
Richmond, VA 23231
800-446-9823**



Safety Section

WARNING

Read and understand this entire manual before operating, maintaining or repairing the leaf vacuum.



DANGER

DO NOT RIDE, SIT OR STAND ON UNIT.

**RIDING ON UNIT
COULD RESULT IN BODILY
HARM OR FATAL INJURY
USE EXTREME CAUTION WHEN
UNIT IS IN USE, OR IN MOTION.**

If the decal above is missing or damaged call ODB immediately and we will send you a replacement free of charge. Never operate a unit with damaged or missing safety decals.

 DANGER





DO NOT RIDE, SIT OR STAND ON UNIT

 DANGER

DO NOT MODIFY THE UNIT FOR RIDERS IN ANY WAY. SERIOUS INJURY OR DEATH MAY OCCUR

ODB's leaf collectors are NEVER to be used to accommodate riders. If your unit has been modified to accommodate riders, remove these modifications immediately as this can result in serious injury or death.

DIESEL REGEN CHART

Indicators	Description	Operator Action
Exhaust Filter Cleaning Indicator 	Active when: 1. Exhaust gas temperature is high. 2. Elevated idle is active. 3. Exhaust filter cleaning is in process.	Machine can be operated as normal. If operating in an area where high exhaust temperatures may be an issue, abort exhaust filter cleaning by using the disable feature.
Exhaust Filter Indicator 	Active when: Soot level in the exhaust filter indicates need for an exhaust filter cleaning.	Enable auto filter cleaning to allow a cleaning cycle. OR Begin a manual / parked cleaning.
Exhaust Filter and Warning Indicators 	Active when: Machine performance is reduced due to moderately high soot level.	Begin a manual / parked cleaning.
Exhaust Filter and Stop Indicator 	Active when: Exhaust filter requires service. Machine performance is reduced due to Extremely High soot level and a stop engine request is made.	Service the exhaust filter. Contact your servicing dealer.
Auto Cleaning Disabled Indicator 	Active when: Auto exhaust filter cleaning is disabled.	If possible, enable auto cleaning.

⚠ WHEN THE UNIT IS UNDERGOING REGEN, WHETHER IT BE AUTOMATIC OR MANUAL, DO NOT TURN THE MACHINE OFF! THIS IS HIGHLY DETRIMENTAL TO THE UNIT. ALLOW IT TO FINISH ITS PROCESSES.

IF YOU NEED TO STOP THE CLEANING, USE THE INHIBIT BUTTON TO STOP THE REGEN PROCESS AND MOVE TO A SAFE AREA TO RESUME

⚠ IF YOU HAVE A 74HP OR BELOW: THERE WILL BE A "LOW DEF FLUID" ICON ON THE SCREEN, THIS IS NORMAL.

75HP AND ABOVE: THE SCREEN CAN MONITOR YOUR DEF LEVELS AND NOTIFY YOU WHEN IT IS BELOW OPTIMAL LEVELS

Municipal Products
Since 1910



Municipal Products
Since 1910

**5118 Glen Alden Drive
Richmond, VA 23231
800-446-9823
www.odbco.com or
www.leafcollector.com**

THANK YOU

Thank you and Congratulations on your purchase of your ODB Leaf Collector. Your ODB leaf collector has been carefully designed and manufactured to give you a maximum amount of dependability and years of trouble-free operation. Take comfort in the fact the ODB has been manufacturing municipal products since 1910 and takes pride in our product's quality and our customer service.

Please take the time to thoroughly read this manual, as well as the engine manual, in its entirety before operating, maintaining, servicing or repairing your leaf collector. Please thoroughly review and follow all the safety procedures located in this manual.

Whenever you need replacement parts, service information or any question regarding your ODB product please feel free to contact us at 800-446-9823 or www.odbco.com.

Please record the following information for future reference:

Model No.:	_____
Serial No.:	_____
Vin No:	_____
Engine Serial No.:	_____
Date of Purchase:	_____

Safety Section

⚠ WARNING

Read and understand this entire manual before operating, maintaining or repairing the leaf vacuum.



DO NOT RIDE, SIT OR STAND ON UNIT.

**RIDING ON UNIT
COULD RESULT IN BODILY
HARM OR FATAL INJURY
USE EXTREME CAUTION WHEN
UNIT IS IN USE, OR IN MOTION.**

If the decal above is missing or damaged call ODB immediately and we will send you a replacement free of charge. Never operate a unit with damaged or missing safety decals.

⚠ DANGER

DO NOT RIDE, SIT OR STAND ON UNIT

⚠ DANGER

DO NOT MODIFY THE UNIT FOR RIDERS IN ANY WAY. SERIOUS INJURY OR DEATH MAY OCCUR

ODB's leaf collectors are NEVER to be used to accommodate riders. If your unit has been modified to accommodate riders, remove these modifications immediately as this can result in serious injury or death.

Safety Section





WARNING

Read and understand this entire manual before operating, maintaining or repairing the leaf vacuum.

1.1 Safety Symbol Definitions

This manual provides the owners/operator with procedures for safe operation, maintenance and repair of your leaf collector. As with any machine, there are hazards associated with their operation. For this reason safety is emphasized throughout this manual. To highlight specific safety information the following safety definitions are provided to assist the reader.

The purpose of safety symbols are to attract your attention to possible dangers. The safety symbols, and their explanations, deserve your careful attention and understanding. The safety warnings do not by themselves eliminate any danger. The instructions or warnings they give are not substitutes for proper accident prevention measures.

SYMBOL	MEANING
	SAFETY ALERT SYMBOL: Indicates danger, warning or caution. Attention is required in order to avoid serious personal injury. May be used in conjunction with other symbols or pictographs.
 DANGER	Disregarding this safety warning <u>WILL</u> result in serious equipment damage, injury or possible death.
 WARNING	Disregarding this safety warning <u>CAN</u> result in serious equipment damage, injury or possible death.
 CAUTION	Disregarding this safety warning <u>MAY</u> result in minor or moderate injury or property damage.

Safety Section

WARNING

Read and understand this entire manual before operating, maintaining or repairing the leaf vacuum.

1.2 Do's and Do Not's:

This section contains some general safety precautions to do and not to do. This is not an all inclusive list and it is the responsibility of the operator to have proper training and use common sense in work situations.

WARNING

DO NOT:

1. **DO NOT** operate, maintain or repair this unit without having fully read and understood ALL the aspects of this manual.
2. **DO NOT** ride, sit or stand on unit at anytime.
3. **DO NOT** modify the leaf vacuum for any reasons to allow for riders.
4. **DO NOT** operate the unit in a state of disrepair.
5. **DO NOT** operate the unit with ANY guards or safety devices broken, missing, or inoperable.
6. **DO NOT** operate the unit without wearing proper safety equipment.
7. **DO NOT** operate this unit while under the influence of any alcohol or medication.
8. **DO NOT** operate this unit if you have a record of mental instability or dizziness which could result in injury to yourself or others.
9. **DO NOT** operate this unit if you are under 18 years of age.
10. **DO NOT** operate this unit without fully inspecting the unit for any damage or leakage.
11. **DO NOT** operate if the unit has any excessive vibration.
12. **DO NOT** operate unit with the inspection door limit switch damaged or missing.
13. **DO NOT** operate unit unless it is properly connected to a leaf collection box.
14. **DO NOT** operate unit unless it is properly attached to the tow vehicle.
15. **DO NOT** tow unit without using all the safety chains.
16. **DO NOT** tow unit with a damaged tongue.
17. **DO NOT** fill fuel tank with engine running. Allow engine to cool for 5 minutes before refueling.
18. **DO NOT** operate unit if fuel is spilled or with fuel cap off.
19. **DO NOT** smoke or weld near the unit.
20. **DO NOT** run engine in an enclosed area.
21. **DO NOT** place hands or feet near moving or rotating parts.

Safety Section

WARNING

Do Not, continued;

22. **DO NOT** operate engine with an accumulation of grass, leaves or other debris on the engine.
23. **DO NOT** run engine with air cleaner removed.
24. **DO NOT** leave leaf machine unattended while in operation.
25. **DO NOT** park machine on steep grade or slope.
26. **DO NOT** vacuum a leaf pile without looking for foreign objects such as metal, glass, plastic or large pieces of wood.

WARNING

Do's:

1. **DO** completely read and understand the owner's manual before operating, maintaining or repairing the leaf collector.
2. **DO** follow engine and PTO manufacturer operating and maintenance instructions.
3. **DO** check fuel lines and fittings frequently for cracks or leaks. Replace if necessary.
4. **DO** completely inspect the unit before leaving the service garage.
5. **DO** check the tow tongue each day for cracks.
6. **DO** inspect and be attentive to what is being vacuumed.
7. **DO** check the impeller, liners and blower housing for cracks or holes daily.
8. **DO** wear proper safety equipment as described in this manual.
9. **DO** watch for pedestrians, animals and other foreign material when vacuuming leaves.
10. **DO** replace any worn or missing safety stickers immediately.

WARNING

Battery posts, terminals and related accessories contain lead and lead compounds, chemicals known to the state of California to cause cancer and birth defects or other reproductive harm. Wash Hands after handling

WARNING

Engine Exhaust, some its constituents and certain vehicle components contain or emit chemicals known to the state of California to cause cancer and birth defects or other reproductive harm.

Safety Section

1.3 Training:

WARNING

Improper use of the ODB leaf collector CAN result in severe personal injury or death. All personnel using this leaf vacuum must be trained and qualified with all the operations, maintenance, repair and safety procedures defined in this manual.

The warnings and procedures regarding safety in this manual are to be used as a guideline only. It is impossible to cover all the events that could happen in the vacuuming process. For this reason, it is vital that the owner accept the responsibility to implement a training program that will provide every operator or mechanic the basic skills and knowledge to make good judgement in all situations.

This training program must include the entire scope of hazards, precautions and government regulations encountered in the vacuuming process. The program should stress the need for regularly scheduled preventive maintenance and detailed equipment safety checks.

It is strongly recommended that all training programs be documented to ensure all operators and mechanics receive initial training on not just the operation but the safety features of the leaf collector.

Safety Section

1.4 Safety Decals

***Read and Follow all Safety Sticker Warnings--Replace all damaged or missing stickers immediately.**



1,2,3,4,5,6,9,
10,11,15

Decals shown on next page

ITEM NO.	PART NUMBER	DESCRIPTION
*	800T19DK	Decal Kit - Trucks (includes 1 -15)
1.	200183	Danger--Rotating Parts
2.	200106	Caution- Pinch Point
3.	200192	Caution - Do Not Operate ... without reading manual
4.	200193	Caution - Allow Engine to Idle
5.	200194	Caution - Do not use Dielectric grease
6.	200178	Danger - Explosion hazard
7.	Call	SCL800 oval sticker
8.	200195	Clean Hopper screens
9.	200181	Warning - Head, Eye and Ear Protection
10.	200109	Do Not Over-Lubricate
11.	200179	Danger - Do Not Ride, Sit or Stand
12.	XVODB2DK	XVAC BIG Sticker
13.	XVODBDK	XVAC SMALL sticker
14.	200177	Warning - Flammable
15.	200182	Warning - Do not open cover while in operation
*Not in Kit	16. *200190	Caution - Unload Body Prop
	17. *200187	Caution - Body must be braced
	18. *Call	Caution - Operation of body prop

Safety Section

1.4 Safety Decals

***Read and Follow all Safety Sticker Warnings--Replace all damaged or missing stickers immediately.**

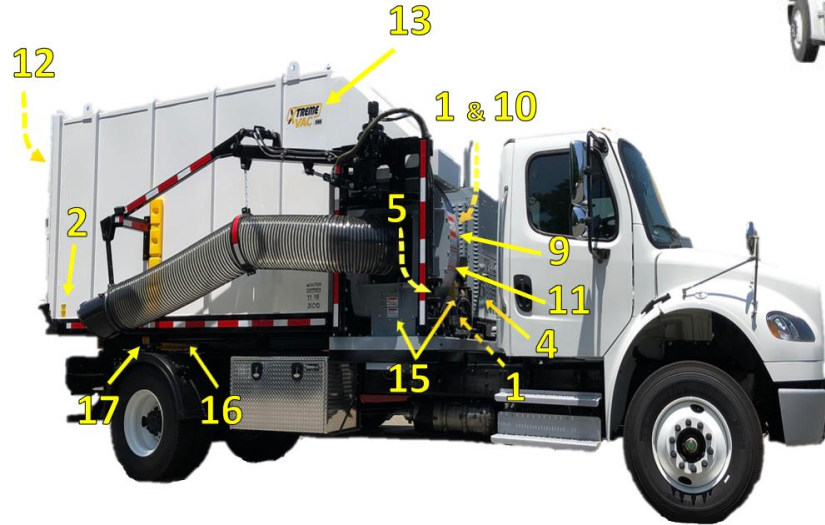

Decals shown on next page

ITEM NO.	PART NUMBER	DESCRIPTION
*	800T19DK	Decal Kit - Trucks (includes 1 - 15)
1.	200183	Danger--Rotating Parts
2.	200106	Caution- Pinch Point
3.	200192	Caution - Do Not Operate ... without reading manual
4.	200193	Caution - Allow Engine to Idle
5.	200194	Caution - Do not use Dielectric grease
6.	200178	Danger - Explosion hazard
7.	Call	SCL800 oval sticker
8.	200195	Clean Hopper screens
9.	200181	Warning - Head, Eye and Ear Protection
10.	200109	Do Not Over-Lubricate
11.	200179	Danger - Do Not Ride, Sit or Stand
12.	XVODB2DK	XVAC BIG Sticker
13.	XVODBDK	XVAC SMALL sticker
14.	200177	Warning - Flammable
15.	200182	Warning - Do not open cover while in operation
*Not in Kit	16. *200190	Caution - Unload Body Prop
	17. *200187	Caution - Body must be braced
	18. *Call	Caution - Operation of body prop

Safety Section

2

⚠ WARNING
ROTATING PARTS



- BEFORE OPERATING READ OPERATORS MANUAL FOR OPERATING AND SAFETY INSTRUCTIONS.
- DO NOT OPERATE WITH ANY GUARDS OR COMPONENT PARTS REMOVED FROM UNIT.
- BEFORE MAKING AND ADJUSTMENTS OR REPAIRS STOP ENGINE AND REMOVE SPARK PLUG WIRE.
- WHILE IN OPERATION KEEP ALL PARTS OF BODY AWAY FROM INTAKE AND EXHAUST SECTIONS.
- WHEN OPERATING MACHINE KEEP PEOPLE AND PETS A SAFE DISTANCE AWAY.

RPODB-10

⚠ ADVERTENCIA
PIEZAS EN ROTACION



- ANTES DE USAR LEA LAS INSTRUCCIONES DE OPERACION Y SEGURIDAD EN EL MANUAL DEL OPERADOR.
- NO OPERE SI CUALQUIER PROTECTOR O COMPONENTE FUE RETIRADO DE LA UNIDAD.
- ANTES DE HACER CUAL QUIERA AJUSTE O REPARACION, DETIENGA EL MOTOR Y RETIRE EL CABLE DE LA BUJIA.
- MIENTRAS ESTA EN OPERACION, MANTENGA ALEJADAS TODAS LAS PARTES DEL CUERPO DE LAS SECCIONES DE ADMISION Y ESCAPE.
- CUANDO LA MAQUINA ESTE EN FUNCIONAMIENTO, MANTENGA A LAS PERSONAS Y MASCOTAS A UNA DISTANCIA SEGURA.

RPODB-10

⚠ CAUTION
PINCH POINT
TO HELP AVOID INJURY FROM FRAME PIVOT AND STOPS
Keep Hands, Feet And Clothing Away

RPODB-30

⚠ PRECAUCION
PUNTO DE ENGANCHE PARA EVITAR HERIDAS DEL PIVOTE DEL BASTIDOR Y LAS PARADAS
aleje las manos, los pies y las prendas de vestir

RPODB-30

4

⚠ CAUTION
DO NOT ATTEMPT TO OPERATE OR REPAIR THIS UNIT WITHOUT FIRST READING AND UNDERSTANDING THE OPERATORS & SERVICE MANUAL

RPODB-20

⚠ PRECAUCION
NO INTENTE OPERAR O REPARAR ESTA UNIDAD SIN PRIMERO LEER Y ENTENDER EL MANUAL DE SERVICIO Y DE OPERACION

RPODB-20

⚠ CAUTION
ALLOW ENGINE TO IDLE BEFORE SHUTTING OFF

RPODB-18

⚠ PRECAUCION
DESACELERE EL MOTOR ANTES DE APAGARLO

RPODB-18

6

⚠ CAUTION
DO NOT USE DIELECTRIC GREASE ON ELECTRICAL SYSTEM. DOING SO WILL VOID WARRANTY.

RPODB-10

⚠ DANGER
EXPLOSION HAZARD
DO NOT CUT, BURN OR WELD WITHOUT FIRST REMOVING OR COMPLETELY PURGING THE FUEL TANK

CONSULT OWNERS MANUAL RPODB-4

⚠ PELIGRO
DE EXPLOSION
NO CORTE, QUEME O SOLDE SIN ANTES ELIMINAR O PURGAR POR COMPLETO EL TANQUE DE COMBUSTIBLE

CONSULTE EL MANUAL DE USUARIO RPODB-4



7

8 CLEAN HOPPER SCREENS EVERY 8-10 HRS

⚠ WARNING
HEAD, EYE AND EAR PROTECTION REQUIRED WHILE OPERATING THIS EQUIPMENT



RPODB-4

⚠ ADVERTENCIA
SE REQUIERE USAR PROTECCION PARA LA CABEZA, OJOS Y OIDOS MIENTRAS OPERA ESTE EQUIPO



RPODB-4

DO NOT OVER-LUBRICATE
BEARING SHOULD BE LUBRICATED EVERY 10-15 HOURS OF OPERATION WITH .2 OZ. (ABOUT 2 STROKES OF AVERAGE GREASE GUN) OF APPROVED LUBRICANT. USE THE ENGINE HOUR METER AS A REFERENCE.

SEE YOUR OWNER'S MANUAL RPODB-28

10

⚠ DANGER
DO NOT RIDE, SIT OR STAND ON UNIT.
RIDING ON UNIT COULD RESULT IN BODILY HARM OR FATAL INJURY
USE EXTREME CAUTION WHEN UNIT IS IN USE, OR IN MOTION.

RPODB-11

⚠ PELIGRO
NO SE SUBA, SIENDE O PARE SOBRE LA UNIDAD.
SUBIRSE A LA UNIDAD PUEDE RESULTAR EN LESIONES GRAVE O LETALES. TENGA EXTREMA PRECAUCION CUANDO ESTA UNIDAD ESTE EN USO O MOVIMIENTO.

RPODB-11



12

⚠ WARNING
FLAMMABLE



RPODB-9

⚠ ADVERTENCIA
FLAMMABLE



RPODB-9

17

⚠ CAUTION

- BODY MUST BE BRACED BEFORE SERVICING HOIST OR WORKING IN AREA WITH BODY IN RAISED POSITION
- LUBRICATE HOIST GREASE FITTINGS OFTEN - AT LEAST EACH TIME TRUCK IS SERVICED
- TRUCK MUST BE LEVEL FOR DUMPING
- DO NOT OVERLOAD

©2015 WEL, INC.

⚠ WARNING
DO NOT OPEN COVER WHILE IN OPERATION

RPODB-11

⚠ ADVERTENCIA
NO ABRA LA CUBIERTA MIENTRAS ESTA EN FUNCIONAMIENTO

RPODB-11

16

⚠ CAUTION
UNLOAD BODY BEFORE USING BODY PROP.

18

OPERATION OF BODY PROP

- Raise body to full height and shut off all power.
- Raise prop to upright position.
- Lower body slowly until body bracket contacts prop.
- DO NOT POWER HOIST DOWN.

Safety Section

1.5 Serial Number Location

WARNING

Thoroughly read and understand the safety and pre-operating sections of this manual before starting the engine.

WARNING

Make sure each operator knows and understands the load ratings of the towed vehicle and that he/she is qualified to tow the vehicle.

The serial number tag is located on the chassis on boom side of the unit. It should be in front of the fenders going toward the front of the unit. (See figure 1.5a).

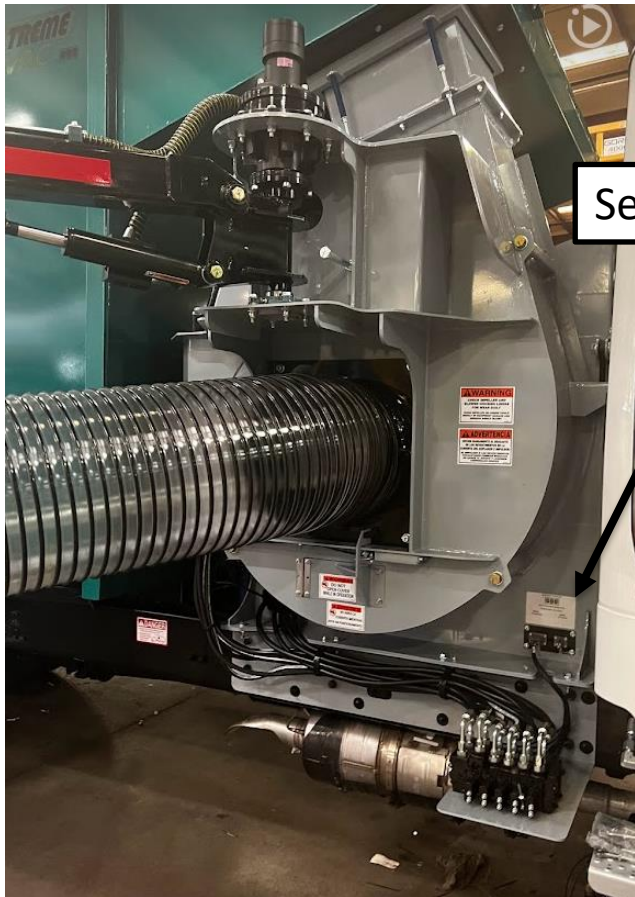

Serial Number Plate



Pre-Operating Section

2.1 Safe Operations:

WARNING

ALL personnel using, maintaining or servicing this unit must be trained in all safety procedures outlined in this manual. Improper or careless use of this equipment CAN result in personal injury or death.

Operations shall be restricted to:

1. Properly trained, qualified and experienced operators and/or qualified and experienced maintenance and test personnel.
2. Trainees under the direct supervision of qualified and experience personnel.
3. Qualified and experienced maintenance and service personnel.

Operators who qualify to operate this equipment under the above restrictions shall also comply with the following physical requirements:

1. Have good vision and the ability to read and understand this manual as well as all safety and operational decals on the equipment.
2. Be capable of hearing, with or without a hearing aid, at a level needed to safely operate this equipment.
3. A record of mental stability with no history of epileptic seizures, dizziness, or any other disability that may result in injury to himself or others.

If any of these requirements are not satisfied at any time, the person failing to meet these requirements **MUST NOT OPERATE THIS EQUIPMENT.**

Pre-Operating Section

2.1 Safe Operations (continued):

Additional Requirements:

1. Each operator must demonstrate competence to understand all safety decals, operator's manuals, safety codes, applicable government regulations, and all other information applicable to the safe and proper operation of the leaf vacuum.
2. Each operator must demonstrate the ability to recognize an emergency situation that may arise during vacuuming operations and the knowledge and procedures to implement corrective action.
3. Each operator must demonstrate or provide evidence of qualification and experience prior to operating the leaf vacuum.
4. Each operator must be able to recognize existing or potential problems regarding the mechanical integrity of the leaf vacuum and report any maintenance requirements to the supervisor in charge.
5. Each operator must wear the proper personal clothing and safety gear. (Refer to SAFETY PRECAUTIONS Section 5.4)
6. Operators must not be physically or mentally fatigued.
7. Operators must not be under the direct or indirect influence of alcohol and/or drugs. This includes prescription drugs that could cause drowsiness, dizziness, or any other condition that would impair their ability to operate or use this equipment in a safe manner.

Pre-Operating Section

2.2 Preparation For Operation

CAUTION

Before your leaf vacuum is put into operation it is very important to read and follow the procedures outlined in the engine owner's manual. (EOM).

For specific information regarding the following checks please refer to the "Maintenance" section of this manual and the engine owner's manual.

WARNING

DISENGAGE the clutch and remove the negative battery cable before performing the following checks.

WARNING

NEVER place any part of the body under or behind guards or any other area in which you cannot see.

IMPORTANT CHECKS:

NOTE: The following checks contained in the next three sections should be performed prior to leaving the storage area.

1. Check engine fuel, coolant and oil levels. (see EOM)
2. Check engine air filter
3. Check all bolts and nuts to ensure they are tight.
4. Check all controls for free and proper operation.
5. Check main drive belt (if equipped) for proper adjustment.
6. Inspect the fan blades to ensure that they are not bent , deformed, fatigued or cracked. Replace fan if any damage is present.
7. Inspect the intake hose flange to make sure it is connected correctly to the blower housing.
8. Inspect the leaf vacuum frame and structure for any bent, broken, cracked, missing or loose parts.
9. Check all guards to ensure they are undamaged, in place and properly secured.
10. All decals must be in place and legible prior to operating the leaf vacuum. See the decal section for decal replacement.

Pre-Operating Section

2.3 Pre-Transport Checks

WARNING

Failure to verify the road worthiness of the leaf vacuum and the truck and verify all equipment is properly stowed, may cause serious injury or death to yourself or others.

Do not tow the leaf vacuum unless all important checks listed below are completed.

IMPORTANT CHECKS:

1. The hose boom is properly secured.
 - a. Be sure nozzle is in the cradle securely.
2. The unit's lighting is operating properly.
3. Check the general condition of the tires, tire pressure and ensure that all lug nuts are securely fastened.
4. Visual examination of the leaf vacuum frame, suspension and structure to determine if all components are correctly positioned and secured for travel.
5. Check the intake hose boom to verify that it is securely fastened to the leaf vacuum and can not swing free.
6. Verify there are no loose tools or materials on the unit, inside the intake and exhaust hoses, or inside the engine sheet metal.
7. Check all cones, wheel-chocks, signs or other support tools and materials to ensure proper stowage.
8. Verify the driver of the unit is qualified to tow the type and weight of the unit.

Pre-Operating Section

2.4 Personal Protective Equipment and Clothing

WARNING

Always wear proper safety equipment as outlined below, not wearing such equipment **CAN** result in serious personal injury or possible death.

IMPORTANT CHECKS:

Anyone operating the leaf vacuum equipment **MUST** wear appropriate protective equipment and clothing to protect them from injury during operations.

PROTECTIVE EQUIPMENT:

1. **Head Protection:** Hard hats without under-chin strapping.
2. **Eye Protection:** Wraparound goggle type eye protection held in place with an elastic band around the head or a hard hat mounted face shield, which provides full protection of the face.
3. Eye protection must meet ANSI Z87.1 standards.
4. **Hearing Protection:** plug type or “muff type” ear protection should be worn at all times while operating the unit.
5. **Breathing Protection:** Paper filter type dust masks should be worn to protect from dirt and dust particles during the vacuuming process.
6. **Reflective Vests:** Highly visible vests should be worn so motorists can see the operator in all weather and lighting conditions.
7. **Work Gloves:** Gloves should be worn to protect the hands and wrists from debris.
8. **Steel Toed Boots:** should be worn to protect the feet.

DANGER

Work clothes **MUST** be close fitting, but not restrictive of movement, without any loose parts that could be entangled in any parts of the leaf vacuum. This includes items such as jewelry, chains and backpacks.

Pre-Operating Section

2.5 Work Site Preparation

WARNING

Never place any part of the body under or behind guards or any other visually obscured area.

Making sure the leaves are clear of possible dangerous material is critical to safe vacuuming. Vacuuming up metal, glass, rocks or other dangerous material CAN cause serious damage to the equipment or personal injury.

The following guidelines must be followed to insure safety.

1. An inspection of the leaves to be vacuumed must be done prior to the vacuuming process. We realize that it is impossible to completely inspect every inch of leaves being vacuumed, but it is imperative that all leaves be inspected for obvious dangerous material before vacuuming.
2. The operator should never be in the line of traffic, the operator should work on the shoulder whenever possible.
3. The operators should place cones or other barriers to provide adequate warnings to vehicles and pedestrians that vacuuming is in progress.
4. Strobe lights on the leaf vacuum and on the tow vehicle should be on at all times for high visibility.
5. Confirm that all operators are wearing proper clothes and personal protective equipment.
6. Restrict all personnel, except the operator from the area near the leaf vacuum. **DO NOT** allow pedestrians, children or animals near the work area.
7. Make sure that the exhaust hose (if equipped) fits properly into the box container so that all debris is blown into the box container.

Operating Section

3.1 Basic Operations

1. Turn on the truck's engine
2. Turn on the ignition switch on the display panel
3. Push the rocker switch on the joystick forward to engage the PTO on the Marmon Herrington Unit
4. All operations of the debris collection system must have the deadman trigger pulled
5. Start fan by pushing on the top yellow push button on the joystick. Continue to tap button until desired fan speed is reached.
6. To operate boom, use joystick to uncradle boom and swing into position. The fan and boom can be operated while the truck is driving up to 20 mph.
7. To dump, go to dump mode while PTO is engaged.
8. Unlatch gate latches using the button on the display.
9. Raise dump up until material leaves hopper.
10. Lower dump until bed down prox is met. This is indicated by the dump down icon adjacent to the button turning green.
11. Close latches until street and curb prox sensors are met. This is indicated by the gate close icon adjacent to the button turning green.
12. Press the joystick rocker back to disengage PTO. The PTO can be disengaged up to 20 mph.
13. Diagnostic mode will indicate the state of all inputs, outputs, faults and variable power divider (VPD) faults.
14. Master mode will allow you to enter any page regardless of machine state. This can be valuable for training or diagnostic work. Please contact your dealer or ODB warranty for the password to enter this state.
15. Each day it is critical that the exhaust ducting is checked for proper adjustment. This seal should also be greased weekly with bearing grease.

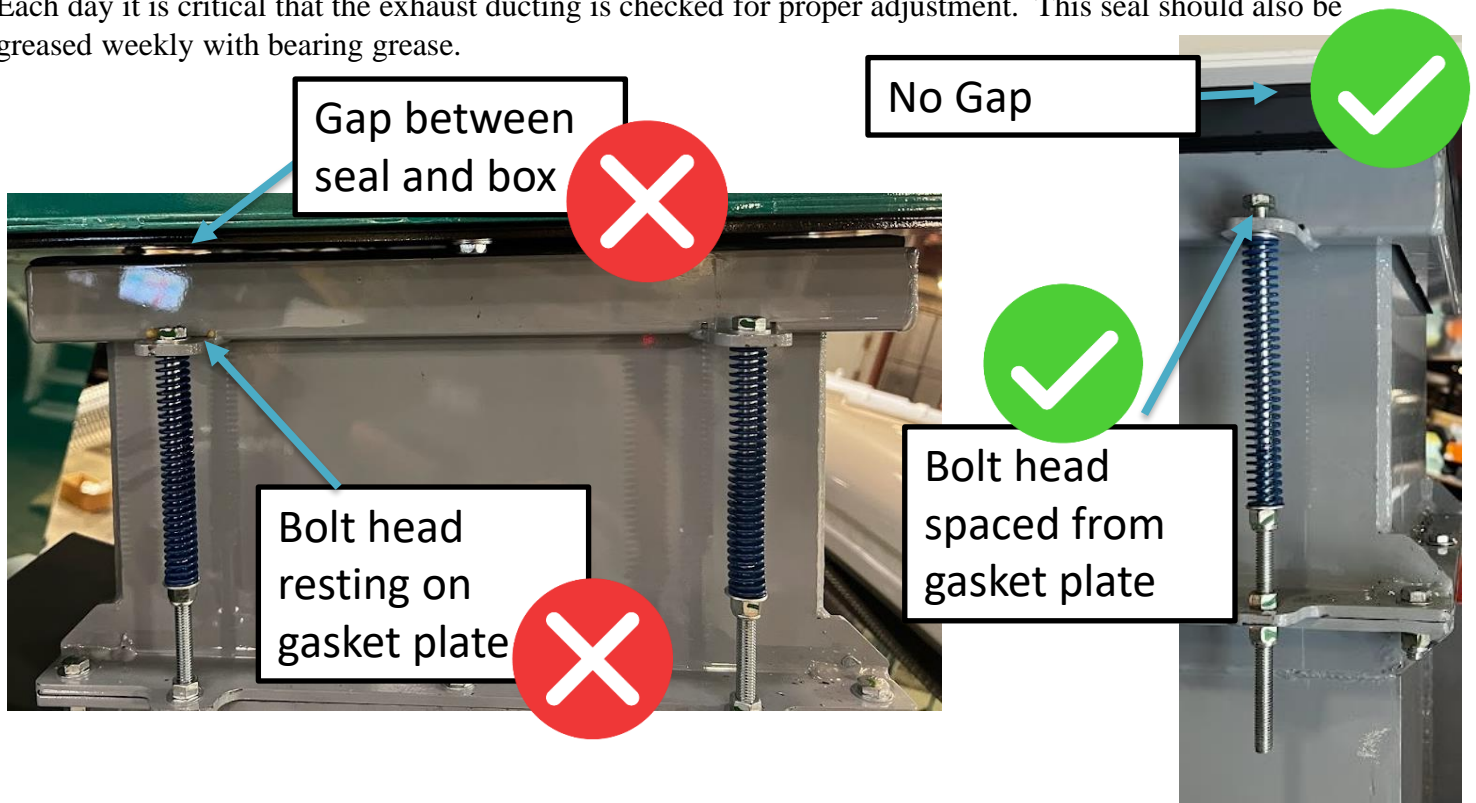

Operating Section

3.8 Joystick

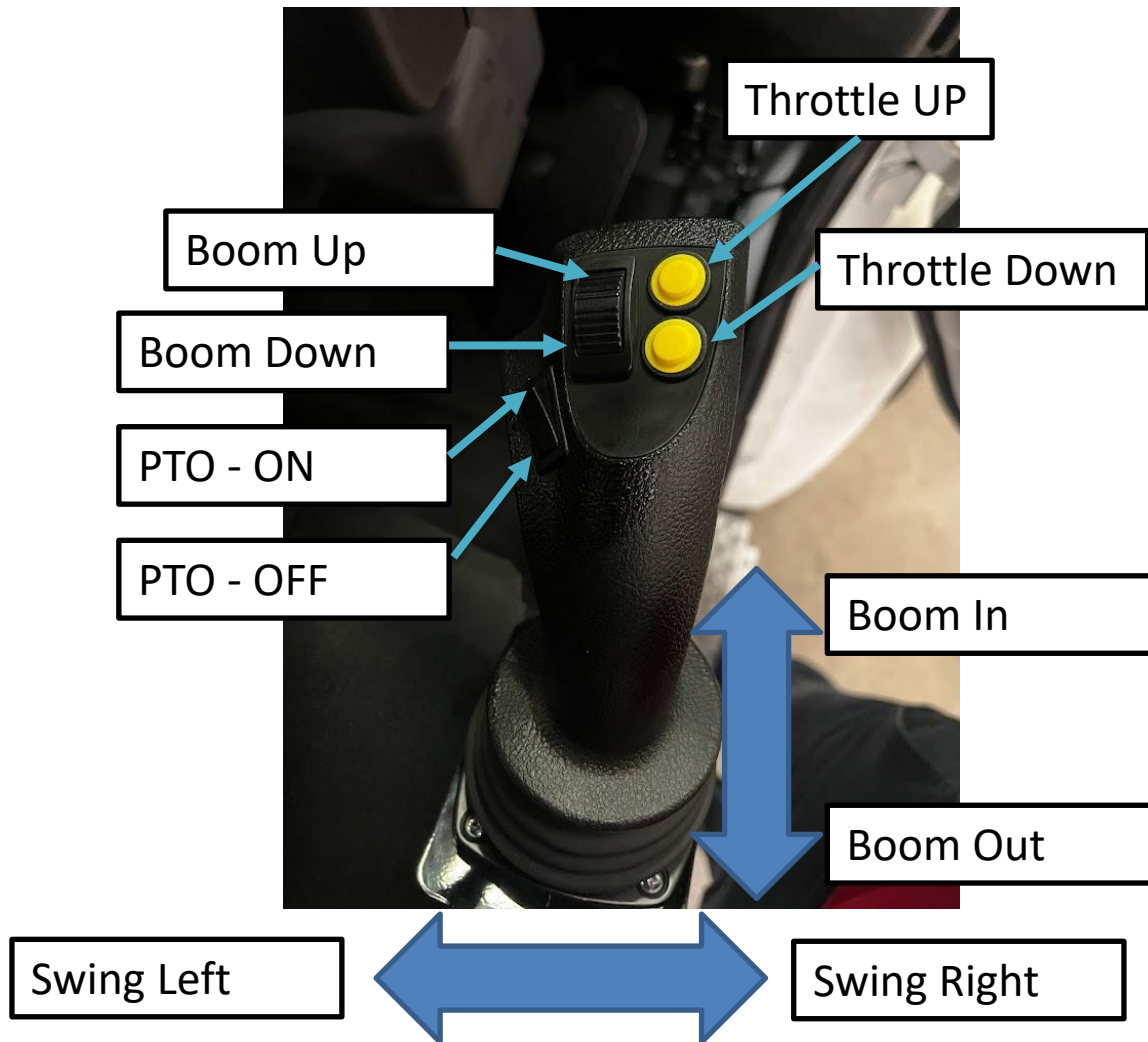

Maintenance Section

4.1 Maintenance Overview:

CAUTION

Only properly trained personnel should perform maintenance or repair on this equipment. Consult ODB before performing any maintenance procedures that is not specifically covered in this manual. Improper maintenance or repair may void any and all warranties on this equipment.

WARNING

Improper maintenance or repair CAN result in equipment damage and/or personal injuries.

DANGER

BEFORE CONTINUING, please read and understand the Safety, Pre-operating and Operating sections of this manual before doing any procedures in this section.

A properly maintained leaf vacuum will dramatically extend the life of the unit and will create a safer work place as well. For the general safety and welfare of all personnel it is important to create a scheduled maintenance program that covers all the elements in this manual as well as the engine, PTO and axle owner's manuals provided with this unit.

Use the chart on the following page as a guide for your scheduled maintenance program. If there are any questions concerning any of these procedures please call ODB.

Maintenance Section

4.2 Maintenance and Lubrication

This chart is only a reference, always **consult the Owners Manual of the Engine, PTO, etc for actual recommendations (Use Hour Meter as a Guide)**

MAINTENANCE	INTERVAL					
	Daily	First 8 Hours	Every 25 Hours	Every 50 Hours	Every 100 Hours	Every 200 Hours
Check and add engine oil, coolant, fuel and Hydraulic fluid (hoist and boom)*	●					
Check for loose nuts or bolts	●					
Check for fuel, oil, coolant and hydraulic leakage*	●					
Check or clean radiator screen	●					
Lubricate impeller shaft flange bearings(if equipped)	●					
Check lug nuts and tire pressure / condition	●					
Check trailer safety chains and hitch	●					
Check tow bar for damage or wear	●					
Check and clean instrument panel and circ. board	●					
Clean pre-cleaner	●					
Check air filter for dirt or debris*	●					
Check trailer lighting and trailer brake operation	●					
Change engine oil* (for break in oil see EOM)		●			●	
Clean and check battery and connections*			●			
Check power band tension (if equipped)			●			
Check power band condition (if equipped)			●			
Check impeller for damage, cracks or wear			●			
Grease (non-conductive) circuit board connectors			●			
Clean hydraulic pump motor/connections			●			
Lubricate throttle and choke cables				●		
Check blower housing liners for cracks or wear				●		
Check Clutch/PTO linkage adjustment				●		
Change hoist hydraulic fluid and filter		●			●	
Change boom hydraulic fluid					●	
Inspect intake and exhaust hoses for damage					●	
Check exhaust duct gasket for wear	●					
Replace oil filter*					●	
Replace air filter primary element*					●	
Inspect radiator and hoses*					●	
Check fan belt conditions and tension*					●	
Inspect all duct work for cracks, holes or wear	●					
Grease / Inspect wheel bearings for corrosion					●	
Change engine coolant*						●
Check fuel tank for leaks						●
Lubricate Hoist and Hinge Fittings						●

* = see the engine owner's manual for complete details

Maintenance Section

4.3 Lubrication:

⚠ CAUTION

Remove the negative battery terminal before attempting any lubrication procedures.

⚠ WARNING

Thoroughly read and understand the safety and pre-operating sections of this manual before performing any lubrication procedures.

Figure 4.3A

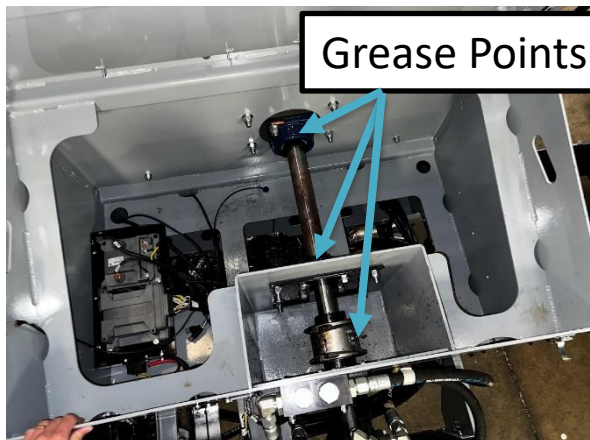

NOTE: DO NOT mix different types of grease. The old grease MUST BE purged before a different type of grease is used. Mixing grease WILL cause premature failure to the bearings.

The following are general lubrication procedures for our standard units. Any special or custom built units may have other lubrication procedures not directly mentioned in this manual. Please consult ODB before any lubricating procedures not specifically mentioned in this manual.

Proper lubrication of your unit correlates directly to how long your unit will last. A properly maintained unit will last much longer than a unit that is not maintained properly.

NOTE: Always lubricate bearings at the end of each work day. This will displace any moisture in the bearings. Also lubricate thoroughly before extended shutdown or storage.

Lubrication Points:

1. **Drive Bearings (figure 4.3a):** These bearings are critical components of the belt-driven units. These bearings should be greased every 10 hours with approximately two strokes from the average hand pump grease gun. The type of grease used in these bearings are also critical to the performance of the bearings. A multi-purpose, heavy-load, high-temperature, moisture resistant #2 grease is required for the drive bearings. ODB recommends Mantek Elite Supreme #1 WG Extreme Duty multi-purpose grease.. Other premium quality grease that matches the above requirements may be used but after years of testing ODB recommends the Elite Supreme grease.



Maintenance Section

Figure 4.3b

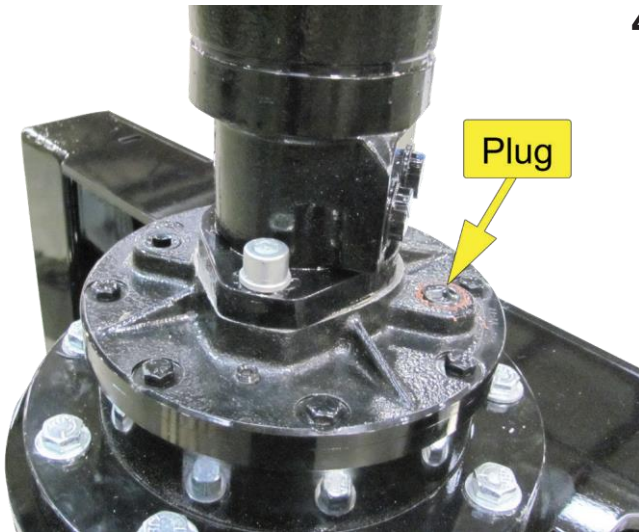

4.3 Lubrication, continued;

Lubrication Points, continued;

1.) Auburn Gear Oil (figure 4.3b): Fill Auburn gear with 90W gear oil. Undue plug as shown and fill. There is a plug at the bottom for draining if necessary.

2.) Boom Swivel (figure 4.3c): Grease the boom bearings once every week with a multi-purpose moisture resistant #2 grease.

3.) Hinge and Friction Points: Leaf vacuum operation and longevity can be improved by keeping hinges and friction points lubricated. ODB recommends that lubrication be performed weekly. Use SAE30 weight oil on hinges and a premium grade, high temperature lithium based EP#2 grease on friction points.

4.) PTO Driveshaft Coupling: To prolong coupling life and trouble free performance, it is recommended that grid couplings be relubricated at least once annually by using a common industrial grade coupling grease. This lubrication interval should be more frequent when the coupling is being subjected to extreme moisture, frequent stops and starts, or excessive vibration.

Figure 4.3c

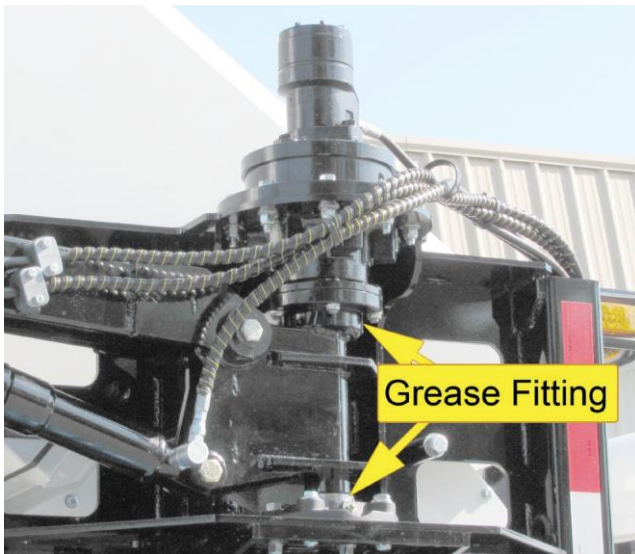

Maintenance Section

4.3 Lubrication, continued;

Lubrication Points, continued:

Figure 4.3e

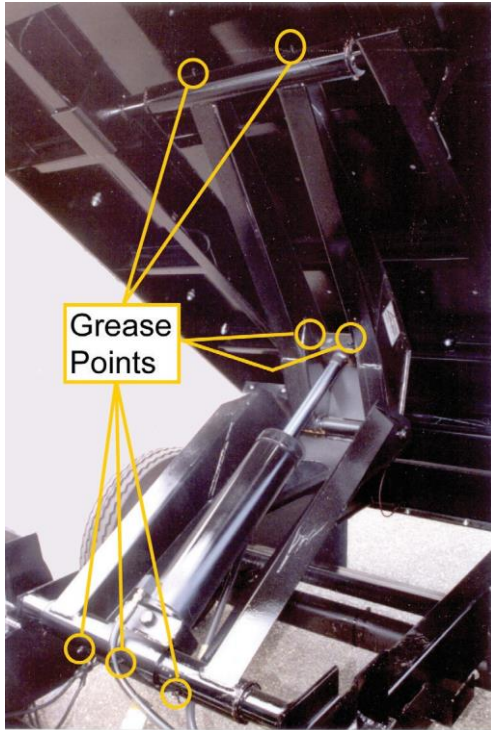

⚠ WARNING

Never go under the dump body unless the body is empty and the body prop(s) is in the proper position.

⚠ WARNING

The body prop is designed and intended to support an EMPTY truck body in the raised position. Unload the body before using the body prop(s).

5.) Hydraulic Hoist Fittings (figure 4.3e): Raise and support the dump body as detailed in section 3.2. Lubricate the fittings at least every 200 hours of operation with a #2 high grade grease. There are tremendous forces on the bearing surfaces within the hoist frame. It pays to be generous with the grease gun, to insure proper operation and long life.

6.) Hoist Hinge and Body Prop(s) Fittings (figure 4.3f): Each hinge pivot has a grease fitting that needs lubricating every 200 hours. The body prop(s) has a fitting at the pivot area as shown in figure 4.3f.

Figure 4.3f

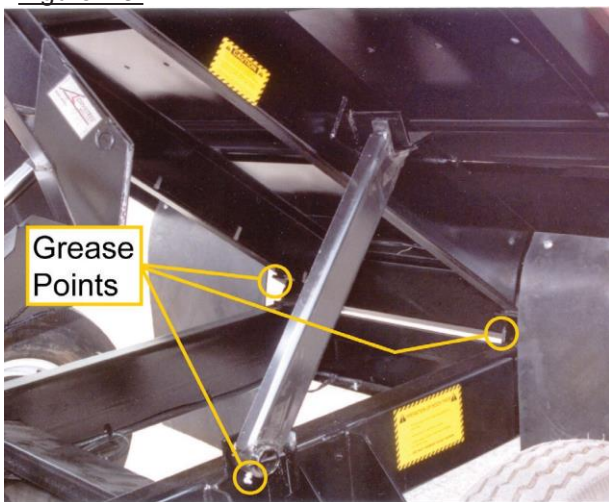

Maintenance Section

4.3 Lubrication, continued;

Lubrication Points, continued;

⚠ WARNING

Never go under the dump body unless the body is empty and the body prop(s) is in the proper position.

⚠ WARNING

The body prop is designed and intended to support an EMPTY truck body in the raised position. Unload the body before using the body prop(s).

7.) Boom Cylinders (figure 4.3j): Grease the pivot joints of the boom cylinder with a high temperature lithium based EP#2 grease once a week.

Maintenance Section

4.4 Preventative Maintenance

⚠ CAUTION

Remove the negative battery terminal before attempting any maintenance procedures.

⚠ WARNING

Thoroughly read and understand the safety and pre-operating sections of this manual before performing any maintenance procedures.

The following are general preventative maintenance procedures for our standard units. Any special or custom built units may have other preventative maintenance procedures not directly mentioned in this manual. Please consult ODB before doing any preventative maintenance procedures not specifically mentioned in this manual.

Proper preventative maintenance of your unit, just like lubrication, correlates directly to how long your unit will last. A properly maintained unit will last much longer than a unit that is not maintained properly.

Preventative Maintenance:

1. **Engine Oil:** Change the oil and oil filter according to schedules provided in your engine's owner's manual (EOM). The engine oil level should be checked every day. The level should be checked after the engine has been stopped for a period of time. This will allow the oil to drain back into the oil pan, allowing a better indication of the true oil level. If the level is low, see the engine's owner's manual for the correct type of oil.
2. **Engine Coolant:** Check the coolant level before starting the unit each day. The coolant level should not be less than one inch below the top of the radiator.

⚠ CAUTION

NEVER check the engine coolant when the engine is hot. Allow the engine to cool at least one hour before checking the coolant. Check the engine owner's manual for instructions. **ALWAYS** wear eye and hand protection when working with the radiator.

Maintenance Section

4.4 Preventative Maintenance, continued;

Preventative Maintenance, continued;

3. **Engine Radiator:** The engine radiator on a leaf vacuum becomes clogged with dust and debris frequently because of the nature of the job. If the radiator is not cleaned properly it WILL cause improper cooling and WILL eventually cause serious damage to your engine. The debris accumulating on the radiator can be lessened by lowering the RPM on the engine to a level just enough to vacuum the leaves. The higher the RPM the more dust that is put into the air. Also, it may be necessary to put mesh or tarps on the top of the leaf box container to reduce the debris and dust. If this is done, make sure there is enough air ventilation on the box so the box is not blown apart. Proper belt condition and coolant mix-ratio, as well as coolant conditioners, are all critical to proper engine cooling. See the engine owner's manual for specifics on coolant mixture ratios and conditioners. The radiator should be inspected and cleaned with compressed air everyday at the very least.

DANGER

NEVER attempt to clean or inspect the radiator with the engine running or while the engine is HOT. Allow the engine to cool at least one hour before maintaining the radiator. Check the engine owner's manual for instructions. ALWAYS wear eye and hand protection when working with the radiator.

4. **Engine Air Cleaner:** Due to the large amounts of dust generated in collection leaves, it is critical to your engine's life that the pre-cleaner and air filter be maintained properly. The pre-cleaner should be cleaned at least daily of any debris that has accumulated. If conditions warrant it should be cleaned more. The air filter should be checked daily and should be replaced at the first sign of it being dirty. DO NOT attempt to clean the air filter, replace the dirty air filter. It is a good idea to clean out the air filter housing once a week to clean any dust debris that may have accumulated.
5. **Tires and Wheels:** Tires and wheel lug nuts should be checked on a daily basis. Tires should be checked for excessive wear and proper air pressure. Check the side wall of the tire for proper inflation pressure. Torque all 1/2" diameter lug nuts from 90 to 120 foot pounds. Torque all 5/8" diameter lug nuts from 175 to 225 foot pounds. Consult the axle manufacturer's owner's manual for more detailed information.

Maintenance Section

4.4 Preventative Maintenance, continued;

Preventative Maintenance, continued;

6. **Trailer Brakes (if equipped):** Most of the newer ODB leaf vacuums have electric brakes on the axle(s). It is critical that these brakes work properly. The trailer's brakes should be checked daily, before leaving the equipment yard, for proper operation. The trailer brakes are designed to work in synchronization with your tow vehicles brakes. Never use your tow vehicle or trailer brakes alone to stop the combined load. The synchronization between the tow vehicle and the leaf vacuum is accomplished through the brake controller and needs to be set correctly. Please read the brake controllers manual and the axle owner's manual for these procedures.

⚠ WARNING

DO NOT tow the leaf vacuum with damaged or non-operating brakes. Check the brakes daily for proper operation.

The brakes should be adjusted after the first 200 miles of operation when the brake shoes and drums have "seated" and at 3,000 mile intervals, or as use and performance requires. The adjustment procedures are beyond the scope of this manual, please see the axle owners/service manual for specific instructions.

The trailer brakes should be inspected and serviced at yearly intervals or more often as use and performance requires. Magnets and shoes must be changed when they become worn or scored thereby preventing adequate vehicle braking. Again, see the axle owner's/service manual for specific procedures.

7. **FUEL TANK:** Fill the fuel tank at the beginning of the work shift leaving a gap of at the top of the tank for expansion of fuel. A full fuel tank will reduce the possibility of condensation forming in the tank and moisture entering the fuel lines. Check the fuel lines daily for cracks, holes or tightness.

Maintenance Section

4.4 Preventative Maintenance, continued;

Preventative Maintenance, continued;

CAUTION

ALWAYS wear eye and hand protection when working with the battery.

8. **BATTERY:** ODB's units are supplied with "maintenance free" batteries so there is no need to check fluid levels but the battery terminals should be checked daily for corrosion. Remove any corrosion with a wire brush and coat the terminals with light grease or petroleum jelly to reduce the possibility of corrosion. Also check the battery cable for wear all cable connections and battery tie downs to be certain that they are not loose.
9. **DRIVE BELT (if equipped):** The main drive belt should be checked daily for cracks and for proper tension. If the belt shows any sign of

CAUTION

Remove the negative battery cable before opening the belt guard.

cracking it should be replaced immediately. The proper tension of the belt should be approximately 1/2" deflection when applying a 8 pound pull.

10. **FASTENERS:** Fasteners should be checked weekly for the first 30 days and monthly thereafter. They must be in place at all times and properly torqued. For general torque values see the torque chart at the end of this section.
11. **INSTRUMENT PANEL AND CIRCUIT BOARD:** The instrument panel and circuit board should be cleaned with compressed air daily. Also the circuit board connectors should be wiped clean and have non conductive grease applied weekly to help maintain solid connections.
12. **BOOM HYDRAULIC PUMP:** Check the fluid level daily. If fluid needs to be added, automatic transmission fluid (ATF) is recommended. Clean debris and oil off the solenoid and pump daily. A build up of debris can cause premature failure to the pump. Check and tighten all hydraulic fittings making sure there are no leaks.

Maintenance Section

4.4 Preventative Maintenance, continued;

Preventative Maintenance, continued;

13. **Hoist Hydraulic Fluid and Filter:** The hoist hydraulic fluid and filter should be changed every 100 hours of operation. The fluid should be completely drained and fresh high quality **ISO 68 non-foaming** hydraulic fluid should be added.





CAUTION

ALWAYS raise and support the box container properly using the steps outlined in this manual.

14. **Exhaust Duct Gasket:** The 1.5" thick gasket should be checked for wear every 200 hours. This gasket creates a tight seal between the box container and the blower housing.
15. **Axle Hangers:** The hanger bolts should be checked periodically for tightness and wear.
16. **Hydraulic Fittings:** Check all hydraulic fittings for leaks and tightness. Any leak could become a hazard, fix immediately.

Maintenance Section

4.5 Torque Values

<u>INCH BOLT AND CAP SCREW TORQUE VALUES</u>					<u>METRIC BOLT AND CAP SCREW TORQUE VALUES</u>						
TYPE	SAE GRADE					CLASS					
	5		8			8.8 or 9.8		10.9		12.9	
HEAD MARK					HEAD MARK						
SIZE(D)	LB-FT		LB-FT		SIZE(D)	LB-FT		LB-FT		LB-FT	
	Lub*	Dry*	Lub*	Dry*		Lub*	Dry*	Lub*	Dry*	Lub*	Dry*
1/4"	7	9	10	12.5	M6	6.5	8.5	9.5	12	11.5	14.5
5/16"	15	18	21	26	M8	16	20	24	30	28	35
3/8"	26	33	36	46	M10	32	40	47	60	55	70
7/16"	41	52	58	75	M12	55	70	80	105	95	120
1/2"	63	80	90	115	M14	88	110	130	165	150	190
9/16"	90	115	130	160	M16	140	175	200	255	240	300
5/8"	125	160	175	225	M18	195	250	275	350	325	410
3/4"	225	280	310	400	M20	275	350	400	500	460	580
7/8"	360	450	500	650	M22	375	475	540	675	625	800
1"	540	675	750	975	M24	475	600	675	850	800	1000
1-1/8"	675	850	1075	1350	M27	700	875	1000	1250	1150	1500
1-1/4"	950	1200	1500	1950	M30	950	1200	1350	1700	1600	2000
1-3/8"	1250	1550	2000	2550	M33	1300	1650	1850	2350	2150	2750
1-1/2"	1650	2100	2650	3350	M36	1650	2100	2350	3000	2750	3500

***Lub** means coated with a lubricant such as engine oil, or fasteners with phosphate or oil coatings. "Dry" means plain or zinc plated without any lubrication.

DO NOT use these values if a different torque value or tightening procedure is given for a specific application. Torque values listed are for general use only. Check tightness of fasteners periodically.

Make sure fastener threads are clean and that you properly start thread engagement. This will prevent them from failing when tightening. Fasteners should be replaced with the same or higher grade. If higher grade fasteners are used, these should only be tightened to the strength of the original.

Tighten plastic insert or crimped steel-type lock nuts to approximately 50 percent of the dry torque shown in the chart, applied to the nut, not the bolt head.

 **CAUTION**

**DO NOT ATTEMPT TO OPERATE
OR REPAIR
THE LEAF COLLECTOR WITHOUT FIRST
READING AND UNDERSTANDING THIS
MANUAL**

IF YOU HAVE ANY QUESTIONS CONCERNING THE
INSTALLATION OR OPERATION OF THIS UNIT, PLEASE CALL
ODB FOR ASSISTANCE BEFORE ATTEMPTING TO REPAIR OR
OPERATE THE UNIT.

**IMPROPER USE OF ANY MACHINE CAN
RESULT IN SERIOUS INJURY!**

**STUDY AND FOLLOW ALL SAFETY
PRECAUTIONS BEFORE OPERATING OR
REPAIRING UNIT**

THIS MANUAL IS AN INTEGRAL PART OF THE LEAF COLLECTOR AND SHOULD
BE KEPT WITH THE UNIT WHEN IT IS SOLD.

**ODB COMPANY
5118 Glen Alden Drive
Richmond, VA 23231
800-446-9823**





5.0 SERVICE SECTION

5.0 Service and Troubleshooting

5.10 Wiring Diagrams

5.20 Hoist Hydraulic System

ODB COMPANY
5118 Glen Alden Drive
Richmond, VA 23231
800-446-9823

Service Section

5.1 Removing Blower Housing Face

figure 5.1a

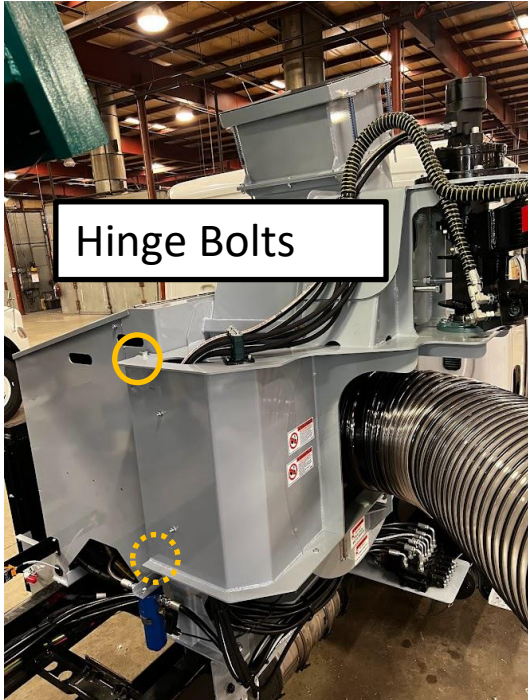
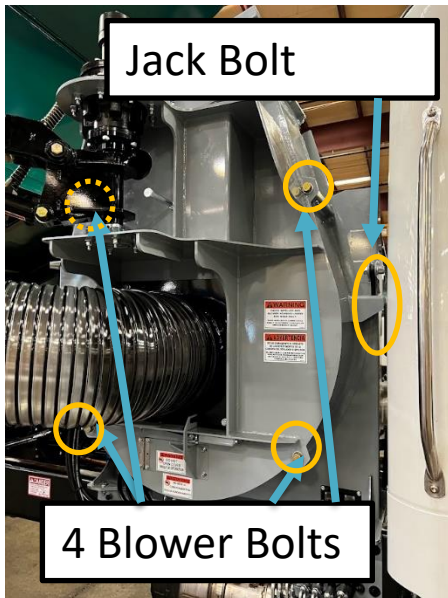

figure 5.1b



⚠ WARNING

Thoroughly read and understand the safety and pre-operating sections of this manual before working on the unit.

⚠ WARNING

Make sure the negative battery cable is disconnected before opening the blower housing.

Review the safety section of this manual before attempting these procedures.

Removing Blower Housing Face (refer to 5.1a and 5.1b):

1. Raise the dump body and secure it as described previously in this manual, making sure the body prop is in place. Position the boom to be straight out from the blower
2. Unbolt the 4 blower bolts holding the blower in place (figure 5.1b).
3. Lower the blower using the jack bolt.
4. Swing out the blower 90 degrees on the hinge bolts (figure 5.1a).
5. To install reverse the above procedure.

Service Section

5.2 Replacing the Drive Bearings(if equipped)

⚠ WARNING

Thoroughly read and understand the safety and pre-operating sections of this manual before working on the unit.

⚠ WARNING

Make sure the negative battery cable is disconnected before opening the blower housing.

Review the safety section of this manual before attempting these procedures.

Removing Drive Bearings (refer to 5.3a thur 5.3d):

1. Remove the impeller and drive belt as described in this manual.
2. If the bearings have not "seized" onto the shaft then removal is straightforward.
3. Remove the bearing collar (Item# 8, fig. 5.3b), if equipped, at the rear of the front bearing (the bearing closest to the blower housing).
4. On the rear bearing (closest to the engine) loosen the set screw on the bearing lock collar (fig. 5.3c)
5. Using a punch, loosen the lock collar. (fig. 5.3d)
6. Pull the shaft out toward the blower housing. The bearing plate, front bearing and pulley should come out in one unit.

figure 5.3b

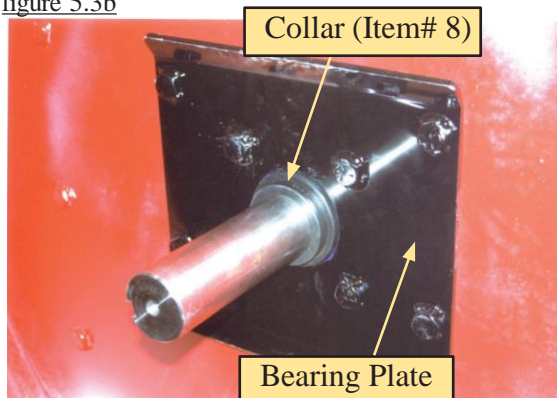

figure 5.3c



figure 5.3d



Service Section

5.3 Impeller Installation and Removal

REMOVAL



CAUTION: Before removing the blower housing face remove the negative battery cable to ensure unit can not be started.

1. The blower housing face must be removed to gain access to the impeller. Use an overhead crane or forklift to support the face while removing.
2. Once the face has been removed, remove the shaft protector (Fig. 1 or 2).
3. Saturate the shaft and bushing using a penetrating lubricant to help loosen the bushing. Clean any grease or debris from the bushing and shaft.
4. Remove the 3 bolts attaching the bushing to the impeller. (Fig. 3) Being careful not to break the bolts. If a set screw is on the lip of the bushing, loosen it using an allen wrench. (Fig. 4)
5. Using two of the bolts that were just removed screw those bolts into the threaded holes on the bushing. Drive the two bolts into the bushing. (Fig. 5) This will separate the bushing from the impeller. Alternate from one bolt to the other driving only about a 1/4" at a time to keep the bushing coming out straight. It is imperative to keep the bushing straight to remove it.

IMPORTANT: Be sure to drive the bushing out evenly or it will get in a bind making removal much harder.

6. If the bushing does not come off using the two bolts, drill and tap several additional 3/8-16 holes around the bushing. Using Grade 8, 3/8-16 - 2 inch bolts, alternately drive the bolts 1/4" at a time to remove the bushing. **KEEP THE BUSHING STRAIGHT** while removing.

IMPORTANT: If additional holes were drilled in the bushing, it can not be reused. It must be replaced.

7. Once the bushing has been removed use an overhead crane or other suitable device to help lift the impeller out of the blower housing.
8. At this point it would be a good idea to inspect the blower housing liners and blower housing for any damage or wear. Any damage or wear to the liners should be fixed by replacing the liners immediately.

Fig. 1



Fig. 2



Fig. 3



Fig. 4

Direct
Drive



Fig. 5

Belt
Drive



Service Section

5.3 Impeller Installation and Removal, continued

INSTALLATION



CAUTION: Before removing the blower housing face remove the negative battery cable to ensure unit can not be started.

1. Clean the shaft of any debris and remove any rust using a 120 grit emory cloth.
3. Using an overhead crane or other suitable lifting device lift the impeller on to the shaft. Turn the impeller to align the keyways of the shaft with the keyway in the impeller.
4. Insert key into the keyway. A light sanding of the keyway may be needed, as well as a few light blows with a rubber mallet.
5. Tap the bushing onto the shaft aligning the keyways.
6. **BELT DRIVE UNITS:** Align the bushing and key to be flush with the end of the shaft (Fig 1).
- DIRECT DRIVE UNITS:** The bushing and key should protrude from the shaft about 1/2 inch (Fig. 2).
7. Put the 3 bolts into the non-threaded holes and drive them into the impeller holes evenly. Alternate between the three bolts as you drive the bolts in. Torque to 40 to 50 lbs/ft. There should be a gap of 3/8" to 1/2" between the bushing and the impeller.

IMPORTANT: Slowly spin the impeller by hand making sure that the back of the impeller is not hitting any of the bolt heads located at the back of the blower housing.

8. If the bushing has a set screw on it, tighten the screw snug with an allen wrench (Fig. 3). This will help keep the key in place.
9. Install the shaft protector on to the shaft (Fig. 4 or 5).

Fig. 1



Fig. 2



Fig. 3



Fig. 4

Direct
Drive



Fig. 5

Belt
Drive



Service Section

5.4 Replacing the Blower Housing Liners

figure 5.5a

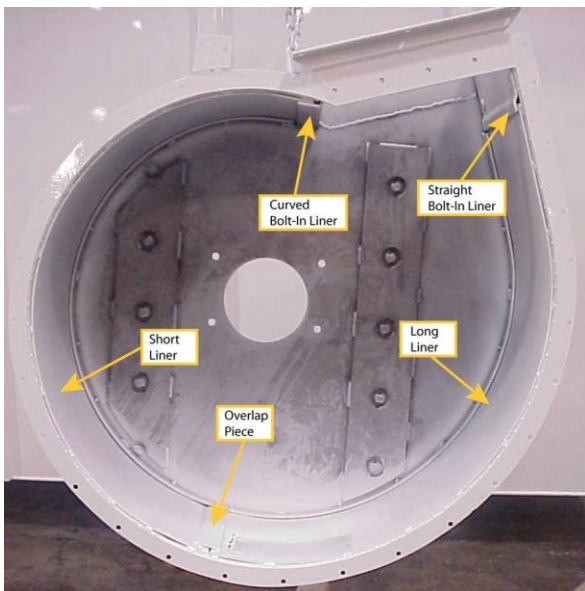

⚠ WARNING

Keep all fuel and fuel fumes away from the unit when grinding or welding. Work only in a well ventilated area.

figure 5.5b

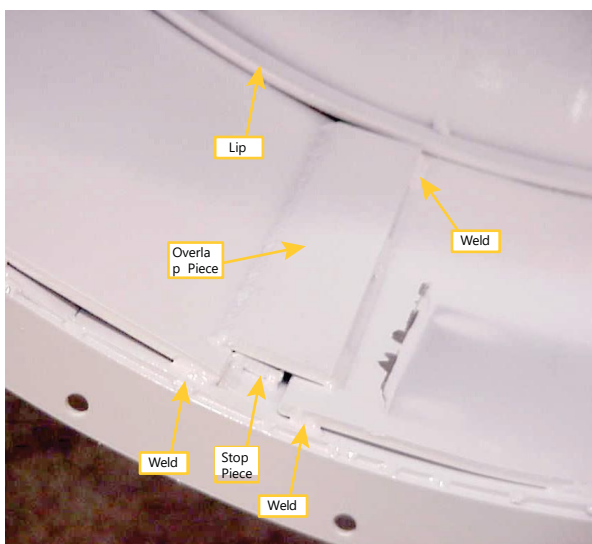

⚠ WARNING

Thoroughly read and understand the safety and pre-operating sections of this manual before working on the unit.

⚠ WARNING

Make sure the negative battery cable is disconnected before opening the blower housing.

Review the safety section of this manual before attempting these procedures. To gain access to the interior of the blower housing please see the previous sections.

Removing and installing the Liners (refer to 5.5a and 5.5b):

1. Unbolt the blower housing face as described previously in this manual.
2. Remove the curved and straight bolt-in liners by removing the appropriate bolts.
3. With a grinder cut out the remaining welds to free the liners. DO NOT remove the "stop piece" at the bottom of the housing.

TO INSTALL:

1. Place the short liner into lip at the rear of the housing and line up the bottom of the liner with the "stop" at the bottom of the housing. The short liner has the overlap piece on it and should be installed as shown in the pictures at the left.
2. Tack weld the liner in place every 8 to 10 inches to help keep the liner in place.

Service Section

5.4 Replacing the Blower Housing Liners; continued,

figure 5.5a

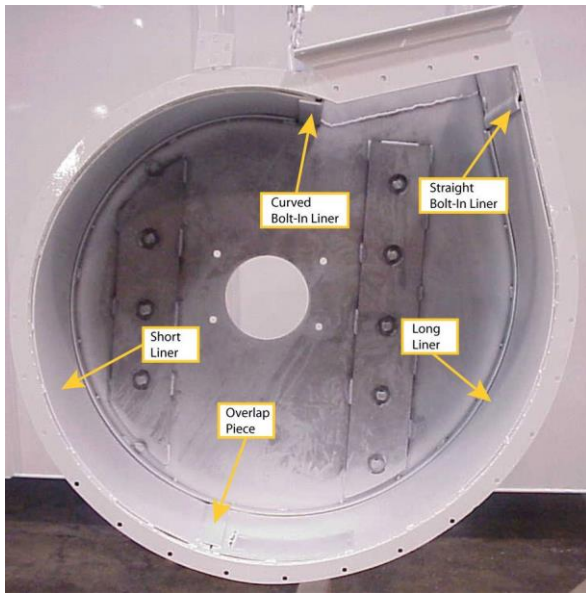

⚠ WARNING

Keep all fuel and fuel fumes away from the unit when grinding or welding. Work only in a well ventilated area.

figure 5.5b

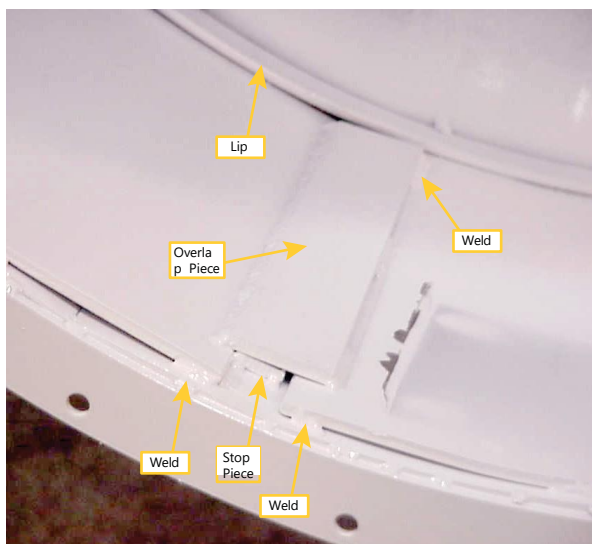

⚠ WARNING

Thoroughly read and understand the safety and pre-operating sections of this manual before working on the unit.

⚠ WARNING

Make sure the negative battery cable is disconnected before opening the blower housing.

Review the safety section of this manual before attempting these procedures. To gain access to the interior of the blower housing please see the previous sections.

Installing the Liners (refer to 5.5a and 5.5b), continued;

3. Install the long liner the same way as the short liner except the long liner should slip under the overlap piece. Make sure the liner slips under the rear lip and the overlap piece.
4. Tack weld the long liner to the overlap piece and tack weld around the liner as you did on the short liner.
5. Install the two bolt-in liners just as they were removed.

ELECTRONIC AND COMPONENTS GROUP

PART NUMBER:

TCC2029

DESCRIPTION:

**JOYSTICK HOLDER
STRAP AROUND T**



PART NUMBER:

118XZ

DESCRIPTION:

**ARM REST COVER,
FREIGHTLINER**



PART NUMBER:

345XZ

DESCRIPTION:

**JOYSTICK ARM
MOUNT**



PART NUMBER:

PMS526GW

DESCRIPTION:

ARM ASSEMBLY



PART NUMBER:

1190XZ

DESCRIPTION:

**REARVIEW
CAMERA**



PART NUMBER:

12077411

DESCRIPTION:

PIN/CAMERA



PART NUMBER:

338XZ

DESCRIPTION:

PROX SWITCH



PART NUMBER:

1935XZ

DESCRIPTION:

WH,CAB



ELECTRONIC AND COMPONENTS GROUP

PART NUMBER:

1936XZ

DESCRIPTION:

WH,TRUCK FRAME



PART NUMBER:

1937XZ

DESCRIPTION:

WH,SKID



PART NUMBER:

1938XZ

DESCRIPTION:

WH,CONTROL VALVE



PART NUMBER:

1939XZ

DESCRIPTION:

WH,FAN MOTOR



PART NUMBER:

1940XZ

DESCRIPTION:

WH,COOLER



PART NUMBER:

1941XZ

DESCRIPTION:

WH,FILTER



PART NUMBER:

1942XZ

DESCRIPTION:

WH,TANK



PART NUMBER:

1943XZ

DESCRIPTION:

WH,BOX



CONTROLS PARTS LIST

Group	Part Number	Description	Qty
Controls	1703XZ	BKT,BOX,BED DOWN PROX MOUNT	1
	1935XZ	WH,CAB	1
	1936XZ	WH,TRUCK FRAME	1
	1937XZ	WH,SKID	1
	1938XZ	WH,CONTROL VALVE	1
	1939XZ	WH,FAN MOTOR	1
	1940XZ	WH,COOLER	1
	1941XZ	WH,FILTER	1
	1942XZ	WH,TANK	1
	1943XZ	WH,BOX	1
	1944XZ	ASM,SKID,POWER RELAY	1
	1945XZ	DEUTSCH PLUG CONNECTOR 3 PIN	1
	1946XZ	DEUTSCH PLUG WEDGELOCK 3 PIN	1
	1947XZ	DEUTSCH PLUG CONNECTOR 6 PIN	1
	1948XZ	DEUTSCH PLUG WEDGELOCK 6 PIN	2
	1961XZ	WH,HP CONTROLLER	1
	2126XZ	WH,RELAY PWR CABLE	1
	2146XZ	ASM,CONTROLLER,MC050	1
	2147XZ	ASM,CAB,DISPLAY,DP720	1
	2148XZ	ASM,CAB,JOYSTICK,JS1	1
	2151XZ	ASM,CONTROLLER,MC018	1
	2152XZ	ASM,FUSE	1
	338XZ	DCL IM5115 PROX SWITCH	3
	675XZ	CUTLER HAMMER ESTOP	1
	9506023	KEYED IGN SWITCH DUETSCH CONNE	1
	LCT72B	BATTERY CABLE, 4G BLACK 72 IN	1
	STD4000	LIMIT SWITCH BOX PLASTIC SINGL	1

BLOWER HOUSING GROUP

PART NUMBER:

1285XZ

DESCRIPTION:

BLOWER/FACE,
HINGE STYLE

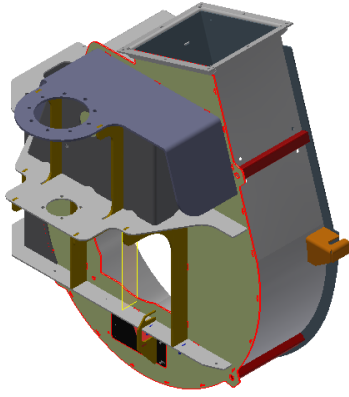

PART NUMBER:

1354XZ

DESCRIPTION:

SKID/PEDESTAL LID
HINGE

PART NUMBER:

1355XZ

DESCRIPTION:

GAS STRUT,
PEDESTAL LID

PART NUMBER:

STD4000

DESCRIPTION:

LIMIT SWITCH BOX

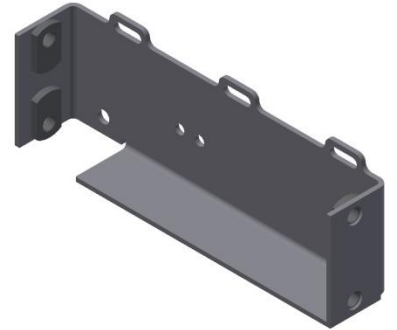

PART NUMBER:

STD4001

DESCRIPTION:

LIMIT SWITCH
ACTUATOR



PART NUMBER:

651051

DESCRIPTION:

LIMIT SWITCH



PART NUMBER:

SCL875002

DESCRIPTION:

INTAKE FLANGE

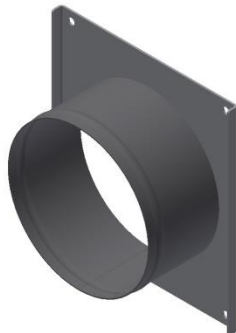

PART NUMBER:

1579XZ

DESCRIPTION:

EXHAUST DUCT
GASKET



BLOWER HOUSING GROUP

PART NUMBER:

SCL621602

DESCRIPTION:

INSPECTION DOOR

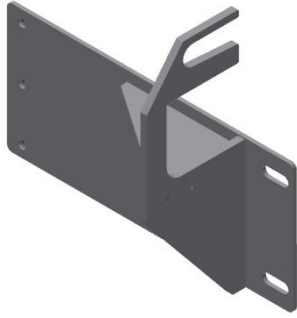

PART NUMBER:

LCT621603

DESCRIPTION:

INSPECTION DOOR
HINGE
(DETAILS ON PAGE
100)

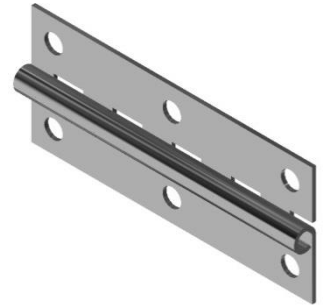

PART NUMBER:

LCT600602

DESCRIPTION:

BEARING PLATE

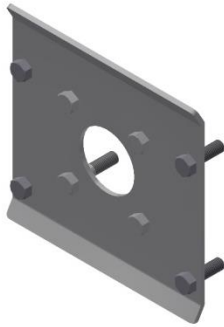

PART NUMBER:

LCT620602A

DESCRIPTION:

LINER BOLT-IN
WRAP ARND

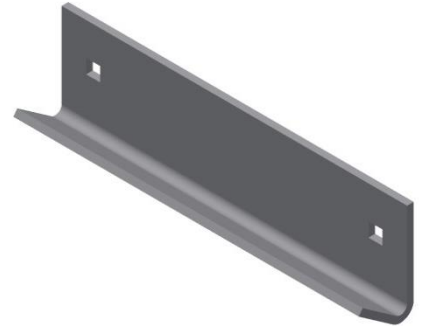

PART NUMBER:

LCT620604

DESCRIPTION:

LINER BOLT-ON
UP TOP

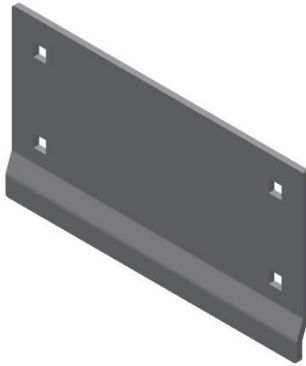

PART NUMBER:

LCT650601

DESCRIPTION:

IMPELLER BUSHING



PART NUMBER:

1070XZ

DESCRIPTION:

IMPELLER 28IN

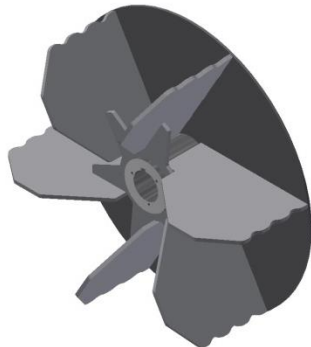

PART NUMBER:

LCT600615

DESCRIPTION:

SHAFT PROTECTOR



BLOWER HOUSING GROUP

PART NUMBER:

LCT650601K

DESCRIPTION:

IMPELLER KEY

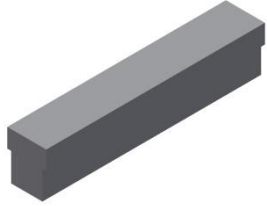

PART NUMBER:

LCT621603

DESCRIPTION:

LINER BOLT
1/2-13X1.25IN FLAT
HEAD



PART NUMBER:

LCT620603N

DESCRIPTION:

LINER NUT
1/2-13 ESN

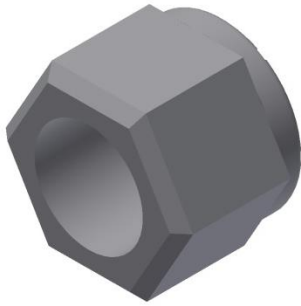

PART NUMBER:

5CZ500750

DESCRIPTION:

IMPELLER BOLT
5/8-11 UNC 2IN

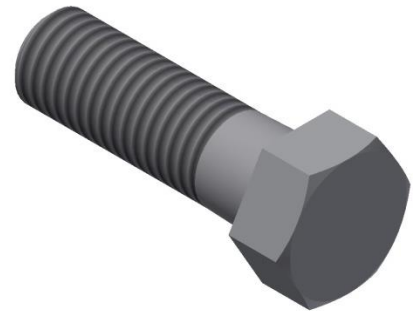

PART NUMBER:

90295A450

DESCRIPTION:

1/4 IN PLASTIC
WASHER
INSTRUME

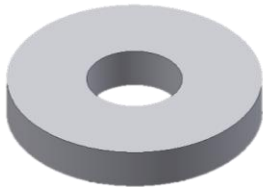

PART NUMBER:

DESCRIPTION:

PART NUMBER:

DESCRIPTION:

PART NUMBER:

DESCRIPTION:

SKID BASE GROUP

PART NUMBER:

1278XZ

DESCRIPTION:

SKID/PEDESTAL,SINGLE ENGINE

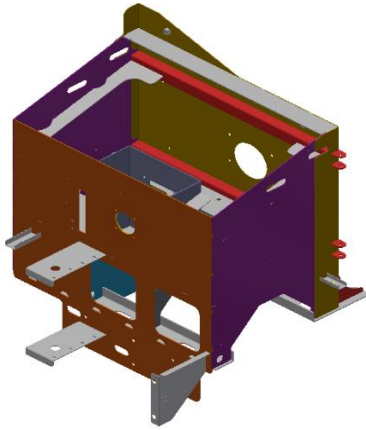

PART NUMBER:

1354XZ

DESCRIPTION:

SKID/PEDESTAL LID HINGE



PART NUMBER:

1355XZ

DESCRIPTION:

GAS STRUT, PEDESTAL LID



PART NUMBER:

1360XZ

DESCRIPTION:

HYD,TANK BRACKET



PART NUMBER:

1373XZ

DESCRIPTION:

HYD,COOLER SWINGOUT

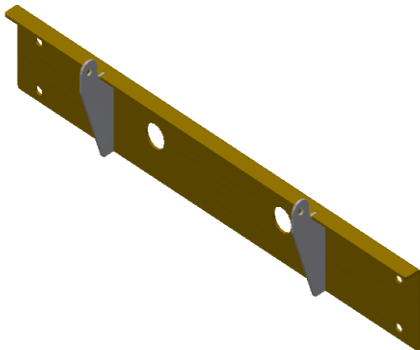

PART NUMBER:

1832XZ

DESCRIPTION:

HYD,COOLER,LATCH BRKT

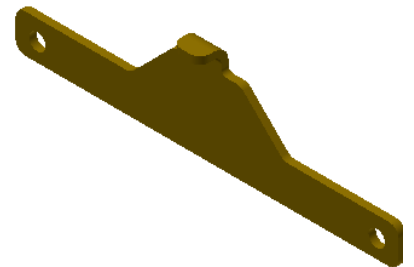

PART NUMBER:

1875XZ

DESCRIPTION:

OIL COOLER, DESTACO LATCH

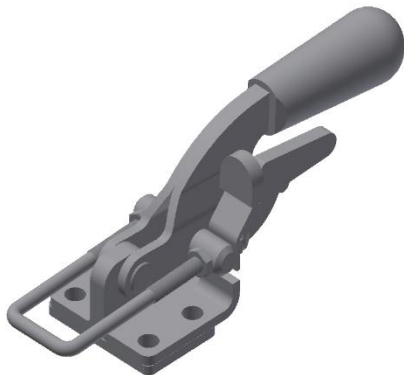

PART NUMBER:

1894XZ

DESCRIPTION:

THRUST WASHER, COOLER



SKID BASE GROUP

PART NUMBER:

TBD

DESCRIPTION:

GREASE HOSE



PART NUMBER:

DESCRIPTION:

PART NUMBER:

272XZ

DESCRIPTION:

OUTER BEARING
PLATE



PART NUMBER:

1353XZ

DESCRIPTION:

SKID/PEDESTAL LID

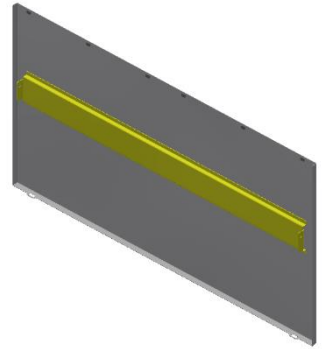

PART NUMBER:

LCT650602A

DESCRIPTION:

4 BOLT BEARING



PART NUMBER:

LCT650602D

DESCRIPTION:

BEARING SPACER
PLATE



PART NUMBER:

LCT600603

DESCRIPTION:

INNER BEARING
PLATE

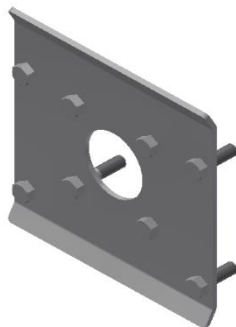

PART NUMBER:

1287XZ

DESCRIPTION:

IMPELLER SHAFT



PEDISTAL GROUP

PART NUMBER:

1512XZ

DESCRIPTION:

**CHA,SKID BRACKET,
CURB SIDE**

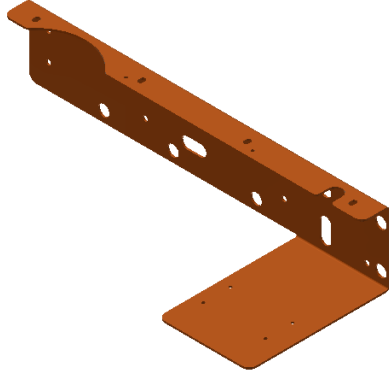

PART NUMBER:

1289XZ

DESCRIPTION:

**SKID/PEDESTAL
LINER**



PART NUMBER:

DESCRIPTION:

PART NUMBER:

DESCRIPTION:

PART NUMBER:

DESCRIPTION:

PART NUMBER:

DESCRIPTION:

PART NUMBER:

DESCRIPTION:
**BELT GUARD
INSPECTION**

PART NUMBER:

DESCRIPTION:

SKID PARTS LIST

Group	Part Number	Description	Qty
Skid	1143XZ	32" CCW STAR IMPELLER	1
	1238XZ	HYDRO-LEDUC BENT AXIS MOTOR	1
	1278XZ	ASM,SKID/PEDESTAL,SINGLE ENG	1
	1285XZ	ASM,BLOWER/FACE,HINGE STYLE	1
	1287XZ	ASM,IMPELLER SHAFT,36.5"	1
	1289XZ	ASM,SKID/PEDESTAL LINER	1
	1290XZ	ASM,GRID COUPLING,MTR/IMP SHFT	1
	1353XZ	ASM,SKID/PEDESTAL LID	1
	1354XZ	ASM,HINGE,4 FT,PEDESTAL LID	1
	1355XZ	ASM,GAS STRUT,50LBS,PEDSTL LID	2
	1360XZ	ASM,HYD,TANK BRKT	2
	1373XZ	ASM,HYD,COOLER SWINGOUT	1
	1512XZ	ASM,CHA,SKID BKT CURB SIDE	1
	1668XZ	ASM,TRUCK,DRIVESHAFT	1
	1702XZ	ASM,HYD,FILTER ASSEMBLY KIT	1
	1832XZ	ASM,HYD,COOLER,LATCH BRKT	1
	1837XZ	ASM,BRKT,PDM/CONTROLLER	1
	1847XZ	ASM,BRKT,HYD VALVE CONNECTOR	1
	1848XZ	ASM,BRKT,CONTROL CONNECTORS	1
	1875XZ	ASM,DESTACO,OIL COOLER	1
	1885XZ	ASM,JACK SCREW BOLT	1
	1894XZ	ASM,THRUST WASHER,COOLER	2
	1904XZ	ASM,BLOWER BOLT,3/4-10	4
	264XZ	DCL 3X BOOM KNUCKLE	1
	272XZ	OUTER BEARING PLATE	1
	719XZ	STAUFF CLAMP PAIR #6	12
	754XZ	4 1/2 PILOT FLANGE BEARING	1
	LCT600603	INNER BEARING PLATE 04/02 - US	1
	LCT609602	LATCH OVERCENTER (JUST LATCH)	2
	LCT620602A	.LINER BOLT-IN WRAP ARND	1
	LCT620604	.LINER BOLT-ON UP TOP	1
	LCT621603	CLEAN OUT DOOR HINGE	1
	LCT650601	Q3 2 1/4 BUSHING	1
	LCT650602A	BEARING IMPELLER BLUE BRUTE	2
	LCT650602D	BEARING SPACER PLATE2/14" BEAR	1
	LINER BOLT PLATE	.LINER CENTER BOLT PLATE	1



8-0

8.0 HYDRAULIC GROUP

8.0 HYDRAULIC GROUP

ODB COMPANY
5118 Glen Alden Drive
Richmond, VA 23231
800-446-9823

HYDRAULIC GROUP

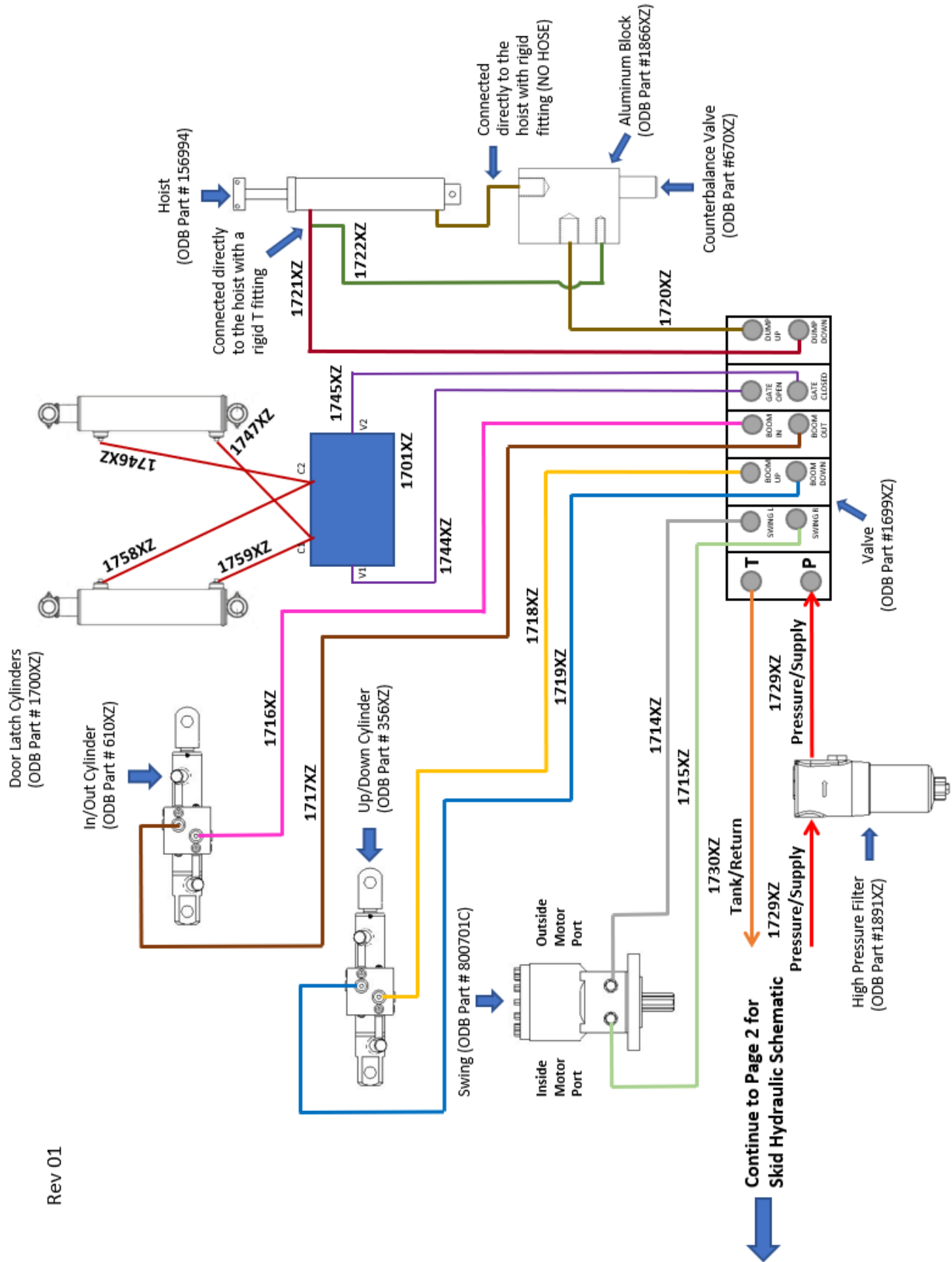

Rev 01

HYDRAULIC GROUP

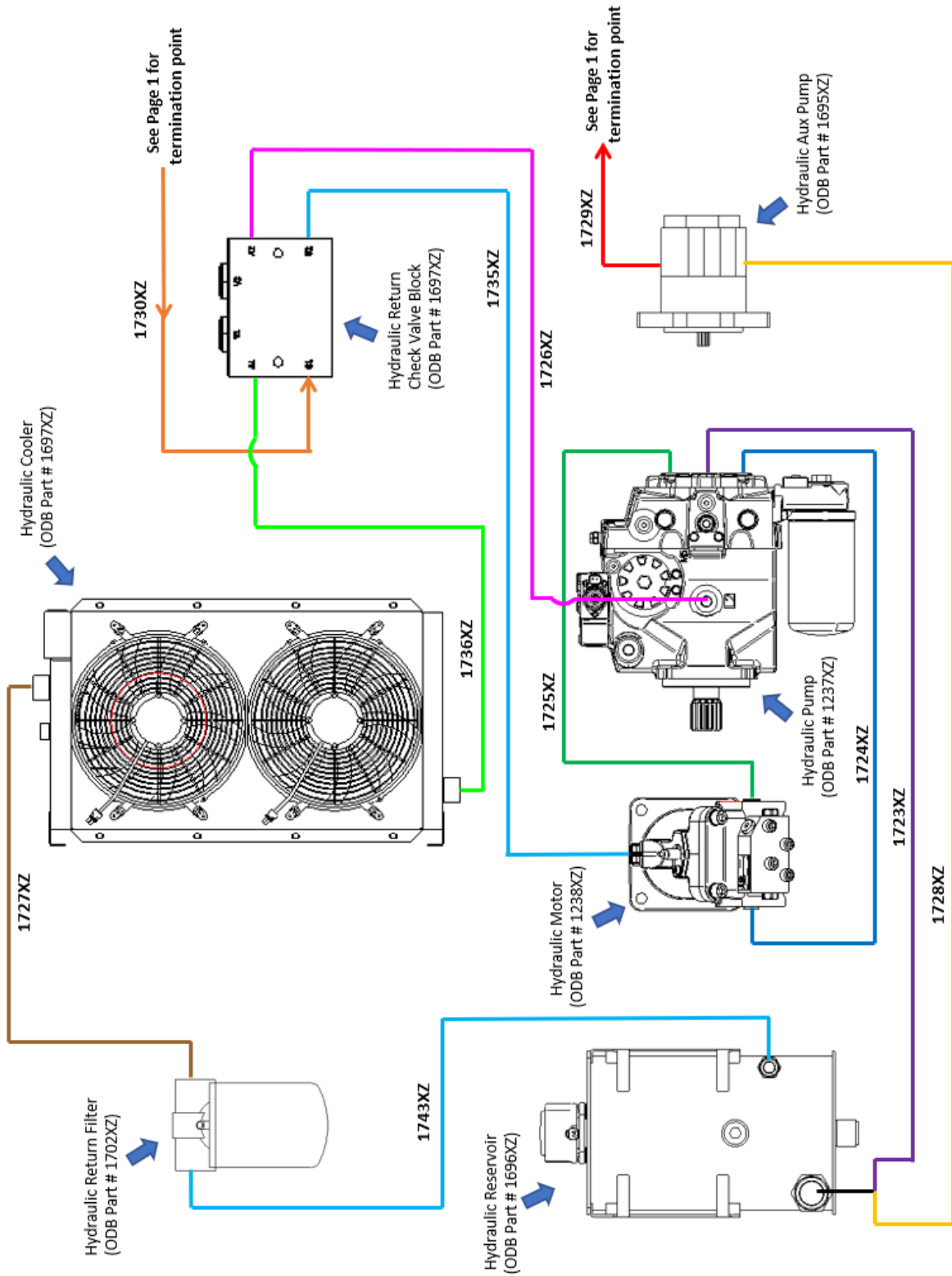

HYDRAULIC PARTS LIST

Group	Part Number	Description	Qty
Hydraulics	1237XZ	PUMP H1P FOR PROJECT 221	1
	1695XZ	ASM,HYD,AUX PUMP	1
	1696XZ	ASM,HYD,CYCLONE RESERVOIR	1
	1697XZ	ASM,HYD,COOLER	1
	1698XZ	ASM,HYD,RETURN CHECK VALVE MA	1
	1699XZ	ASM,HYD,CONTROL VALVE	1
	1700XZ	ASM,BOX,DOOR LATCH CYLINDERS	2
	1702XZ	ASM,HYD,FILTER ASSEMBLY KIT	1
	→1704XZ	→ASM,HYD,FILTER HEAD	1
	→1705XZ	→ASM,HYD,FILTER ELEMENT	1
	→1706XZ	→ASM,HYD,FILTER INDICATOR	1
	1714XZ	HOSE,HYD,SWG/LT,6-130	1
	1715XZ	HOSE,HYD,SWG/RT,6-133	1
	1716XZ	HOSE,HYD,IN/EXT,6-188	1
	1717XZ	HOSE,HYD,OUT/RETR,6-191	1
	1718XZ	HOSE,HYD,UP/EXT,6-157	1
	1719XZ	HOSE,HYD,DWN/RETR,6-160	1
	1720XZ	HOSE,HYD,HOIST_UP/EXT,8-122	1
	1721XZ	HOSE,HYD,HOIST_DWN/RETR,8-156	1
	1722XZ	HOSE,HYD,HOIST/CBV,4-34	1
	1723XZ	HOSE,HYD,PUMP/SPLY,20-84	1
	1724XZ	HOSE,HYD,MTR_A,16-54	1
	1725XZ	HOSE,HYD,MTR_B,16-60	1
	1726XZ	HOSE,HYD,CASE DRAIN,12-60	1
	1727XZ	HOSE,HYD,FILTER/SPLY,12-52	1
	1728XZ	HOSE,HYD,AUX PUMP/SPLY,16-80	1
	1729XZ	HOSE,HYD,VAVLE/SPLY,8-72	1
	1730XZ	HOSE,HYD,VALVE/RET,8-173	1
	1731XZ	HYD,FITTINGS KIT,PROJECT 221	1
	1735XZ	HOSE,HYD,MTR CASE DRAIN,12-30	1
	1736XZ	HOSE,HYD,COOLER/SPLY,12-72	1
	1743XZ	HOSE,HYD,TKN/RETRN,12-20	1
	1744XZ	HOSE,HYD,LATCH/CHECK V1,6-264	1
	1745XZ	HOSE,HYD,LATCH/CHECK V2,6-264	1
	1746XZ	HOSE,HYD,OPEN/RETR,LH,6-72	1
	1747XZ	HOSE,HYD,EXT/CLOSED,LH,6-72	1
	1758XZ	HOSE,HYD,OPEN/RETR,RH,6-72	1
	1759XZ	HOSE,HYD,EXT/CLOSED,RH,6-72	1

HYDRAULIC PARTS LIST

Group	Part Number	Description	Qty
Hydraulics	1891XZ	ASM,HYD,PRESSURE FILTER KIT	1
Cont...	→1895XZ	→ASM,HYD,PRESSURE FILTER	1
	→1896XZ	→ASM,HYD,PRESSURE FILTER INDICATOR	1
	2149XZ	ASM,HYD,PRESSURE TRANSDUCER	1
	2150XZ	ASM,HYD,TEMPERATURE THERMISTOR	1
	2157XZ	HOSE,HYD,VAL/PRESS FILTER,8-60	1
	200007C	HYD OIL, CASTROL 5-20 2&3AXIS	24
	4501411	FITTING 1/8" X 1/8 " SWIVEL GR	2

BOX GROUP

PART NUMBER:

SCL800034

DESCRIPTION:

DOOR SEAL
BRACKET, BOLTS TO
WELDED PIECE ON
BOX



PART NUMBER:

SCL800035

DESCRIPTION:

DOOR SEAL
BRACKET



PART NUMBER:

SCL800036

DESCRIPTION:

TOP,HINGE,BOX,
DOOR,PROP



PART NUMBER:

80092BX

DESCRIPTION:

TOP HINGE BOLT
3/4-10 UNC X
2.75IN LONG



PART NUMBER:

1592XZ

DESCRIPTION:

TOP,HINGE,BOX,
DOOR,PROP

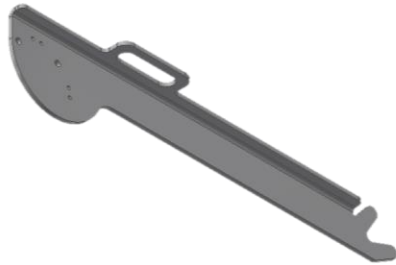

PART NUMBER:

1594XZ

DESCRIPTION:

BELLEVILLE DISC
SPRING



PART NUMBER:

1595XZ

DESCRIPTION:

OVERSIZED FLAT
WASHER



PART NUMBER:

1596XZ

DESCRIPTION:

THICK LEAD
BRONZE THRUST
WASH



LIGHT AND REFLECTOR GROUP

PART NUMBER:

STD2201

DESCRIPTION:

LED MARKER LIGHT,
RED



PART NUMBER:

STD2202

DESCRIPTION:

LED MARKER LIGHT,
YELLOW



PART NUMBER:

STD2213A

DESCRIPTION:

LED STROBE LIGHT
WITH FLASHER



PART NUMBER:

98101ODX

DESCRIPTION:

REFLECTIVE TAPE
RED/WHITE. 2"



PART NUMBER:

STD2414G

DESCRIPTION:

OVAL TAIL LIGHT
GROMMET



PART NUMBER:

STD2414

DESCRIPTION:

LED TAIL LIGHT,
RED



PART NUMBER:

2301XZ

DESCRIPTION:

PLT,BOX,LATCH
COVER

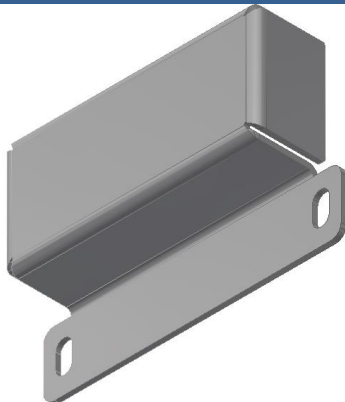

PART NUMBER:

DESCRIPTION:

HOPPER PARTS LIST

Group	Part Number	Description	Qty
Box	155547	.655 HOIST/FLOYD 20YD	1
	1588XZ	FAB,BOOM,HOSE CRADLE	1
	1591XZ	FAB,BOOM,HOSE CRADLE MOUNT	1
	1594XZ	BELLEVILLE DISC SPRING	1
	1595XZ	OVERSIZED FLAT WASHER	1
	1596XZ	THICK LEAD BRONZE THRUST WASH	1
	1788XZ	.FAB,BOX,DOOR	1
	1874XZ	FAB,BOX,25 YD BOX	1
	1880XZ	ASM,NOSE CONE, TOP INLET PLATE	1
	1881XZ	ASM,NOSE CONE,FRNT INLET PLATE	1
	1886XZ	ASM,BOX,DOOR LATCH	2
	1908XZ	TOP,HINGE,BOX,DOOR,PROP	1
	1918XZ	ASM,BODY PROP ARM,DRIVER	1
	1919XZ	ASM,BODY PROP ARM,PASSENGER	1
	733XZ	.SINGLE CYLINDER HYD HOIST KIT	1
	843XZ	DCL COMPLETE BOTTOM EXH SCRN	3
	98101ODX	REFLECTIVE TAPE RED/WHITE. 2"	64
	SCL800030	RUBBER DOOR SEAL	3
	SCL800034	REAR DOOR RUBBER SEAL ANGLE	1
	SCL800035	DOOR RUBBER SEAL ANGLE SIDE OF	2

BOOM ASSEMBLY

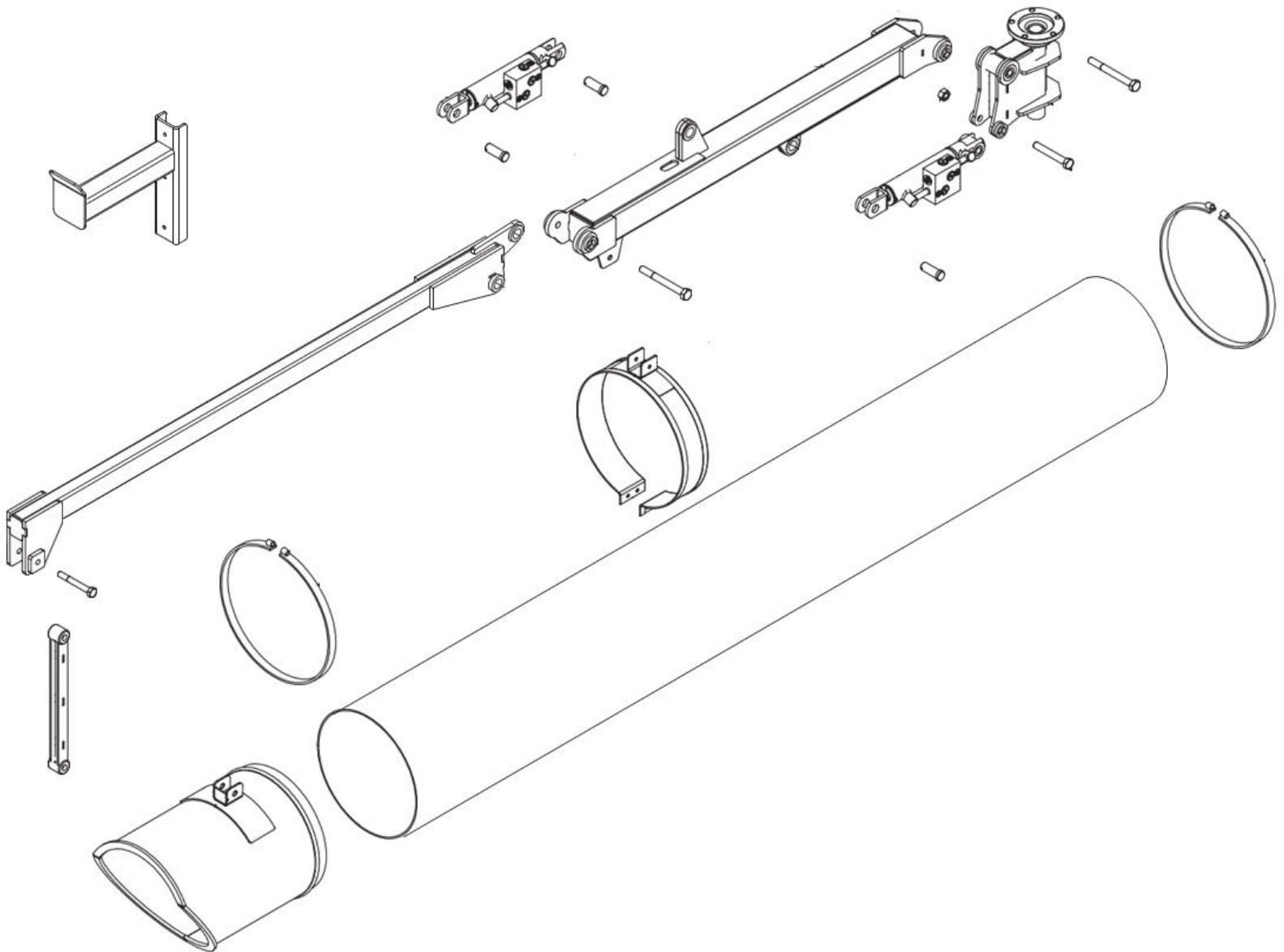

BOOM ASSEMBLY GROUP

PART NUMBER:

266XZ

DESCRIPTION:

UP/DOWN BOOM
ARM

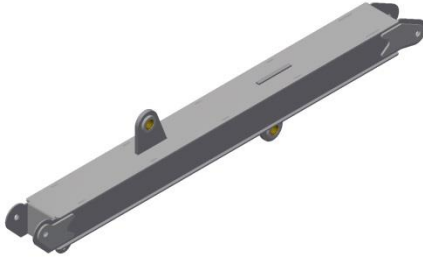

PART NUMBER:

265XZ

DESCRIPTION:

IN AND OUT BOOM
ARM



PART NUMBER:

610XZ

DESCRIPTION:

IN/OUT HYDRAULIC
CYLINDER



PART NUMBER:

356XZ

DESCRIPTION:

UP/DOWN
HYDRAULIC
CYLINDER



PART NUMBER:

LCT616603U

DESCRIPTION:

HOSE SUPPORT
BAND



PART NUMBER:

LCT616601MAHD

DESCRIPTION:

MULTI-AXIS NOZZLE



PART NUMBER:

SCL816813

DESCRIPTION:

HOSE SUPPORT
BAR



PART NUMBER:

264XZ

DESCRIPTION:

BOOM SWIVEL



BOOM ASSEMBLY GROUP

PART NUMBER:

754XZ

DESCRIPTION:

**PILOT FLANGE
BEARING**



PART NUMBER:

800704B

DESCRIPTION:

**AUBURN GEAR
DRIVE**



PART NUMBER:

LCSDH16144W/S

DESCRIPTION:

**URETHANE HOSE
WITH WEAR STRIP**



PART NUMBER:

200048

DESCRIPTION:

**3/8-16 THREADED
ROD 7IN LONG**



PART NUMBER:

800710

DESCRIPTION:

**BOLT 3/4-16 X
7.5IN LONG**



PART NUMBER:

759XZ

DESCRIPTION:

**CLEVIS PIN 1IN X
2.5IN LONG**



PART NUMBER:

760XZ

DESCRIPTION:

**HAIRPIN COTTER
PIN**



PART NUMBER:

DESCRIPTION:

BOOM ASSEMBLY GROUP

PART NUMBER:

LCT616616

DESCRIPTION:
HOSE BAND



PART NUMBER:

585XZ

DESCRIPTION:
OIL EMBEDDED
THRUST WASHER



PART NUMBER:

800701D

DESCRIPTION:
O-RING FOR HYD
MOTOR

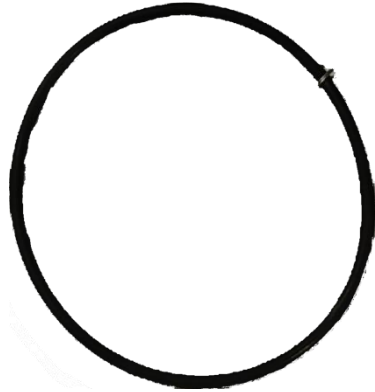

PART NUMBER:

200010

DESCRIPTION:
QUICK LINK 5/16IN



PART NUMBER:

DESCRIPTION:

PART NUMBER:

DESCRIPTION:

PART NUMBER:

DESCRIPTION:

PART NUMBER:

DESCRIPTION:

AUBURN GEAR DRIVE ASSEMBLY

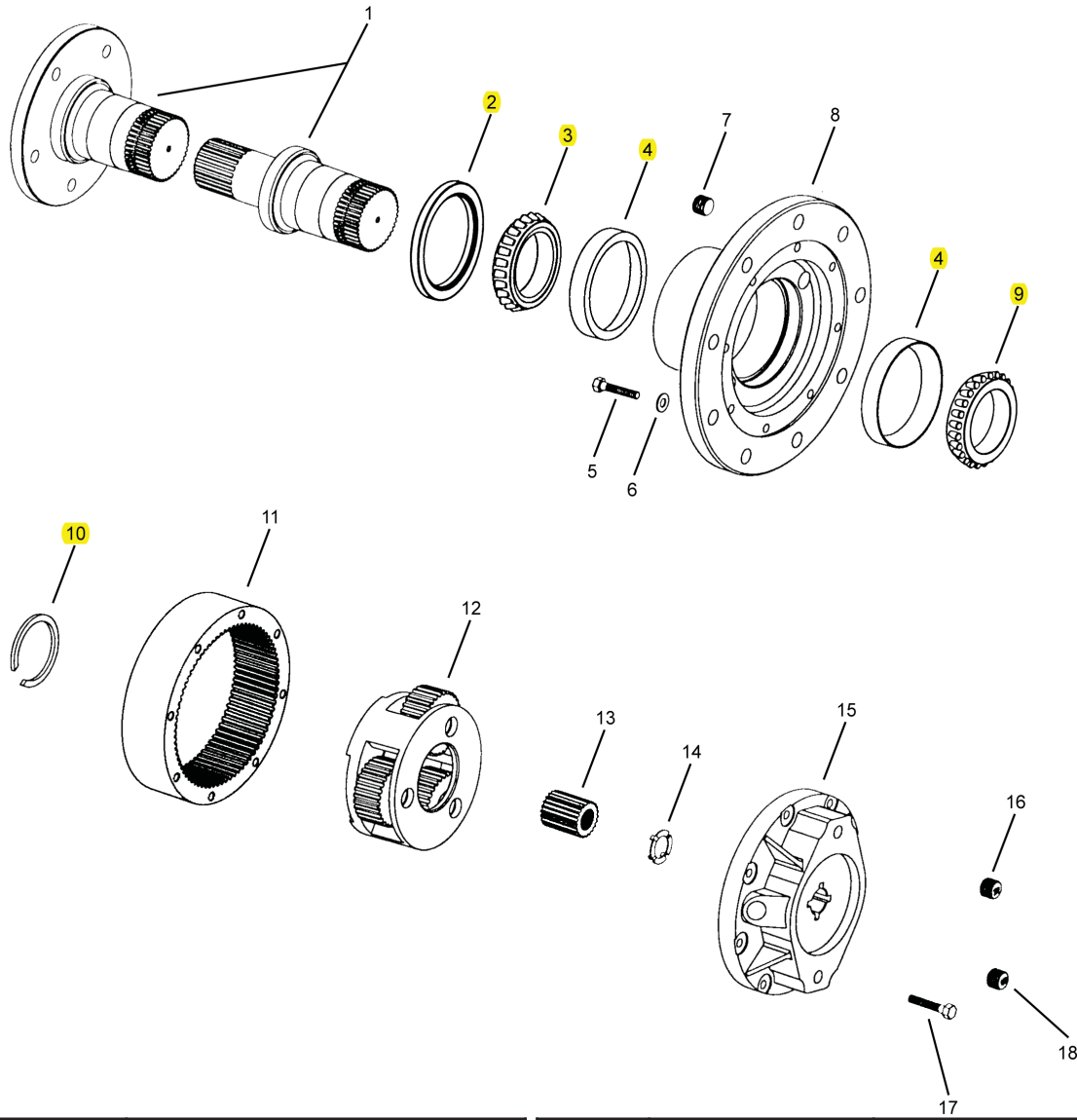

ITEM #	PART #	DESCRIPTION	ITEM #	PART #	DESCRIPTION
1		Output Shaft or Spindle	13		Sun Gear
2	14-00-044-010	Oil Seal	14		Thrust Washer
3	14-01-101-35	Bearing Cone	15		Cover
4	14-01-102-12	Bearing Cup	16	14-00-052-002	Magnetic Plug
5		Hex Head Bolt (grade 8)	17		Hex Head Bolt
6		Flat Washer	18	03-04-101-01	Pipe Plug
7	03-04-101-09	Pipe Plug	*	641008	Bearing and Seal Kit, includes #2,3,4,8 and 10
8		Hub	*	641017	Seal Kit, includes #2 & #10
9	04-01-101-17	Bearing Cone	*	618318	Gear Bolt
10	14-02-410-003	Retaining Ring Kit		618318.N	Nut
11		Ring Gear			
12		Carrier Assembly			

BOOM PARTS LIST

Group	2nd Item Number	Description	Qty
Boom	200008	SNAP SPRING HOOK LCB500	1
	200010	QUICK LINK 5/16 INCH	1
	200048	THREADED ROD3/8-16X7"	2
	2008XZ	BUSHING,BRONZE,CYL	2
	265XZ	IN AND OUT BOOM ARM	1
	266XZ	UP AND DOWN BOOM ARM	1
	356XZ	DCL HYD CYL BOOM UP/DWN W BUSH	1
	585XZ	OIL EMBEDDED THRUST WASHER	4
	610XZ	DCL HYD CYLINDER BOOM IN/OUT	1
	759XZ	CLEVIN PIN 1X2 1/2	2
	760XZ	HAIRPIN COTTER PIN	2
	800701C	EATON HYD MOTOR 3 AXIS BOOM AU	1
	800701D	O RING SEAL HYD MOTOR	1
	800704B	PAINTED AUBURN GEAR DRIVE	1
	800710	BOLT 3X ARM -SPECIAL	2
	90295A450	1/4 IN PLASTIC WASHER INSTRUME	1
	LCSDH16144W/S	URETHANE HOSE WITH WEAR STRIP	1
	LCT600200	CHAIN 1/4" PROOF COIL	1
	LCT616601MAHD	NOZZLE3 AXIS BOOM HEAVY DUTY 4	1
	LCT616603U	HOSE SUPPORT BAND 'U'	1
	LCT616616	HOSE BAND	2
	PMS526GW	ARM ASSEMBLY	1
	SCL816813	HOSE SUPPORT BAR 3/AXIS BOOMS	1
	SCL875002	INTAKE HOSE FLANGE3AXIS BOOMS	2

MISC. PARTS

PART NUMBER:

C070078

DESCRIPTION:

GASKET, 30' ROLL--
3/8"



PART NUMBER:

V710

DESCRIPTION:

75' ROLL 1/8" X
3/4"W BLACK FO



PART NUMBER:

DESCRIPTION:

PART NUMBER:

DESCRIPTION:

PART NUMBER:

DESCRIPTION:

PART NUMBER:

DESCRIPTION:

PART NUMBER:

DESCRIPTION:

PART NUMBER:

DESCRIPTION:

Safety Section

WARNING

Read and understand this entire manual before operating, maintaining or repairing the leaf vacuum.



DANGER

DO NOT RIDE, SIT OR STAND ON UNIT.

**RIDING ON UNIT
COULD RESULT IN BODILY
HARM OR FATAL INJURY
USE EXTREME CAUTION WHEN
UNIT IS IN USE, OR IN MOTION.**

If the decal above is missing or damaged call ODB immediately and we will send you a replacement free of charge. Never operate a unit with damaged or missing safety decals.

 DANGER

DO NOT RIDE, SIT OR STAND ON UNIT

 DANGER

DO NOT MODIFY THE UNIT FOR RIDERS IN ANY WAY. SERIOUS INJURY OR DEATH MAY OCCUR

ODB's leaf collectors are NEVER to be used to accommodate riders. If your unit has been modified to accommodate riders, remove these modifications immediately as this can result in serious injury or death.



CAUTION

**DO NOT ATTEMPT TO OPERATE
OR REPAIR
THE LEAF COLLECTOR WITHOUT FIRST
READING AND UNDERSTANDING THIS
MANUAL**

IF YOU HAVE ANY QUESTIONS CONCERNING THE
INSTALLATION OR OPERATION OF THIS UNIT, PLEASE CALL
ODB FOR ASSISTANCE BEFORE ATTEMPTING TO REPAIR OR
OPERATE THE UNIT.

**IMPROPER USE OF ANY MACHINE CAN
RESULT IN SERIOUS INJURY!**

**STUDY AND FOLLOW ALL SAFETY
PRECAUTIONS BEFORE OPERATING OR
REPAIRING UNIT**

THIS MANUAL IS AN INTEGRAL PART OF THE LEAF COLLECTOR AND SHOULD
BE KEPT WITH THE UNIT WHEN IT IS SOLD.

ODB COMPANY
5118 Glen Alden Drive
Richmond, VA 23231
800-446-9823

